



*Bundesamt für Energie  
Office fédéral de l'énergie  
Ufficio federale dell'energia  
Swiss Federal Office of Energy*

---

Programme  
**Stockage de chaleur**

# **Heat Exchanger Pile System of the Dock Midfield at the Zürich Airport**

## **Detailed Simulation and Optimisation of the Installation**

rédigé par  
**Dr D. Pahud, Dr A. Fromentin**  
**EPFL - LASEN, CH - 1015 Lausanne**

**Markus Hubbuch**  
**Amstein + Walthert Beratende Ingenieure AG SIA**  
**c/o ARGE ZAYETTA**  
**Operations Center, CH - 8058 Zürich - Flughafen**

par ordre de  
**Office fédéral de l'énergie**

## Short Abstract

The Dock Midfield, a new terminal of 500 m long at Zürich airport, will be constructed on 350 foundation piles. About 300 will be used as heat exchanger piles for heating and cooling purposes. The piles are thick, up to a diameter of 1.5 m, which is unusual for heat exchanger piles.

Validated TRNSYS simulation tools are used and adapted for the thermal simulation of the Dock Midfield pile system. The heat exchanger pile system has to be sized and optimised in a proper way, and requires a precise knowledge of the input data.

A response test has been carried out to determine in situ the thermal conductivity of the ground and measure the average ground temperature. The results confirm that no significant ground water movement is present.

A detailed simulation of the pile system reproduces as best as possible the system layout. This latter is improved and an optimal system control is found on the basis of simulation results. The system thermal performances simulated with PILESIM correspond to those obtained with the detailed model. PILESIM is a simulation tool for heating and cooling systems which use heat exchanger piles or multiple borehole heat exchangers.

PILESIM has been developed in the framework of this study. It can be used by people who are not necessarily experts in system simulation and TRNSYS. A great flexibility has been preserved in order to be able to simulate a large variety of system concepts. The required time to define and simulate a system is reasonably short, which is a great advantage for the assessment of an early project and different system concepts.

## Résumé

Dans le cadre de la 5<sup>e</sup> étape de construction de l'aéroport de Zurich, un nouveau terminal de 500 m de longueur, le Dock Midfield, sera construit sur 350 pieux de fondation. Environ 300 pieux seront équipés en pieux échangeurs, et serviront d'échangeur de chaleur avec le terrain. Ils permettront de satisfaire des besoins de chaleur en hiver par l'intermédiaire d'une pompe à chaleur et des besoins de refroidissement en été par refroidissement direct. Le système de pieux échangeurs, comprenant également une pompe à chaleur, un stockage de froid et des échangeurs de chaleur doit pouvoir être correctement dimensionné et optimisé. En outre, la grosseur des pieux utilisés, jusqu'à 1.5 mètre de diamètre, est plutôt inhabituel pour des pieux échangeurs.

Des outils de simulation développés avec le programme de simulation de systèmes thermiques TRNSYS et validés sont utilisés et adaptés pour la simulation du système de pieux échangeurs du Dock Midfield. Le modèle de simulation du système devient de plus en plus détaillé à mesure que le projet évolue et que les informations nécessaires au modèle deviennent plus précises. Celles-ci concernent principalement l'évolution au cours d'une année type de la demande de chaleur et de refroidissement, les caractéristiques des pieux et de la base du bâtiment et ainsi que les caractéristiques du terrain.

Les demandes de chauffage et de refroidissement du bâtiment ont été estimées à plusieurs reprises sur la base d'informations et de modèles de calcul plus détaillés. Le système de pieux échangeurs est à chaque fois simulé et optimisé. Un historique des calculs effectués permet de retracer l'évolution du projet.

Un test de réponse est réalisé pour caractériser les propriétés thermiques du terrain. Il permet de confirmer que l'eau souterraine ne bouge pratiquement pas, de mesurer la température du terrain à 10.3 °C et de déterminer la conductibilité thermique moyenne du terrain pour le dimensionnement du système à 1.8 W/mK. Cette valeur de dimensionnement est environ 10% plus basse que la valeur estimée par le test de réponse, de manière à conserver une marge de sécurité quant à sa variation possible dans le terrain.

La dernière simulation exécutée utilise un modèle détaillé du système qui reproduit au mieux le schéma de principe de l'installation. Ce dernier est amélioré et un contrôle du système optimum est défini sur la base de résultats de simulation. Le modèle détaillé permet également de tester avec succès les performances globales du système simulées avec PILESIM, un outil de simulation de systèmes de chauffage et refroidissement qui utilisent des pieux échangeurs ou des sondes géothermiques multiples.

PILESIM a été développé dans le cadre de cette étude et a bénéficié de l'expérience gagnée dans la simulation de systèmes avec pieux échangeurs. PILESIM a l'avantage de pouvoir être utilisé par des personnes qui ne sont pas nécessairement expertes dans la simulation de systèmes et dans l'utilisation de TRNSYS. Une grande flexibilité est offerte pour pouvoir simuler un large éventail de systèmes. Le temps nécessaire pour définir et simuler un système est raisonnablement court, ce qui est un grand avantage pour l'évaluation d'un avant-projet et de plusieurs variantes.

|   |
|---|
| Cette étude a été accomplie sur mandat de l'Office fédéral de l'énergie. Les auteurs sont seuls responsables du contenu et des conclusions. |
|---|

## **Abstract**

In the framework of the 5<sup>th</sup> building step of the Zürich airport, a new terminal of 500 m long, the Dock Midfield, will be constructed on 350 foundation piles. About 300 piles will be used as heat exchangers which will act as a ground heat exchanger. Connected to a heat pump, the piles will be used to cover heating needs. They will also be used to satisfy cooling needs in the “direct cooling mode” (without the intermediate of a cooling machine). The heat exchanger pile system comprises as well a heat pump, a cold storage and counter-flow heat exchangers. It has to be sized and optimised in a proper way. The thickness of the piles is rather large, up to a diameter of 1.5 m, which is unusual for a heat exchanger pile.

Simulation tools developed with the transient thermal system simulation programme TRNSYS and validated are used and adapted for the simulation of the Dock Midfield pile system. The simulation model is more and more detailed as the project evolves and the accuracy of the necessary input data increase. The input data are mainly the time evolution during a typical year of the heating and cooling demands, the characteristics of the piles and the building basement, and the ground characteristics.

The heating and cooling demands of the building have been estimated at different times, on the basis of more detailed information and calculation models. The heat exchanger pile system is simulated and optimised each time the heating and cooling demand is better known. A historic of the realised calculations is presented.

A response test has been carried out to characterise the thermal properties of the ground. The results confirm that no significant ground water movement is present. The average ground temperature is measured to 11 °C and the mean effective thermal conductivity of the ground is set to 1.8 W/mK for design value. This value is about 10% smaller than the estimation obtained with the response test, in order to account for the possible variation in the ground.

The last simulation of the pile system uses a detailed model which reproduces as best as possible the system layout. This latter is improved and an optimal system control is found on the basis of simulation results. A comparison of the system thermal performances obtained with the detailed model and PILESIM is successful. PILESIM is a simulation tool for heating and cooling systems which use heat exchanger piles or multiple borehole heat exchangers.

PILESIM has been developed in the framework of this study. The experience gained in the simulation of pile systems could be used. PILESIM can be used by people who are not necessarily experts in system simulation and TRNSYS. A great flexibility has been preserved in order to be able to simulate a large variety of system concepts. The required time to define and simulate a system is reasonably short, which is a great advantage for the assessment of an early project and different system concepts.

## **Acknowledgements**

The authors thank the Swiss Federal Office of Energy for its financial support. They also thank the people and firms who were involved in this project.

## **Table of content:**

|   |       |
|---|-------|
| 1. Introduction, objectives.....  | p. 1  |
| 1.1 The Dock Midfield.....  | p. 1  |
| 1.2 Simulation Tools of Pile Systems.....                               | p. 2  |
| 1.3 Main Objectives.....  | p. 2  |
| 1.4 Historic of the Project.....  | p. 2  |
| 1.5 Content of the Report.....  | p. 3  |
| 2. Ground Properties.....   | p. 4  |
| 3. Heating and Cooling Demand and Pile System Thermal Performances..... | p. 5  |
| 3.1 First Estimation of the Heating and Cooling Demand.....             | p. 5  |
| 3.2 Second Estimation of the Heating and Cooling Demand.....            | p. 6  |
| 3.3 Third Estimation of the Heating and Cooling Demand.....             | p. 8  |
| 4. The PILESIM Simulation of Dock Midfield.....                         | p. 10 |
| 4.1 Main Input Parameters for PILESIM.....                              | p. 10 |
| 4.2 Output Results Obtained with PILESIM.....                           | p. 13 |
| 5. Detailed Simulation Model of the System.....                         | p. 16 |
| 5.1 System Layout.....  | p. 16 |
| 5.2 The Winter and Summer Heat Exchangers.....                          | p. 17 |
| 5.3 The System Operational Modes.....                                   | p. 20 |
| 5.4 The System Control.....   | p. 22 |
| 5.5 Main Input Parameters of the Reference System.....                  | p. 28 |
| 5.6 Output Results Obtained with the Detailed Model of the System.....  | p. 28 |
| Conclusion.....   | p. 36 |
| References.....   | p. 37 |

## **Appendix:**

Appendix 1: The PILESIM Simulation Tool

## 1. Introduction, objectives

### 1.1 The Dock Midfield

In the framework of the 5<sup>th</sup> building step of the Zürich airport, a new terminal, the Dock Midfield, is planned. This building, 500 m long and 30 m wide, will be constructed on foundation piles, as the upper layer of the ground is too soft to support the loads of the building. The piles, having a diameter comprised between 1 and 1.5 m, will stand on the moraine, which lies at a depth of about 30m. Among the 350 piles, about 300 will be used as heat exchanger piles. In other words, plastic tubes will be fixed on the metallic reinforcement for the circulation of a heat carrier fluid. Thermal energy can be injected or extracted from the ground. In that way the piles form a heat exchanger with the ground, so called ground heat exchanger. Connected to a heat pump, thermal energy will be extracted from the ground for heating purpose during the winter. During the summer, a thermal recharge is necessary, which is achieved by injecting in the ground part of the thermal loads of the building. The ground volume in the pile region acts as a seasonal storage of thermal energy. A cross section of Dock Midfield is shown in figure 1.1.

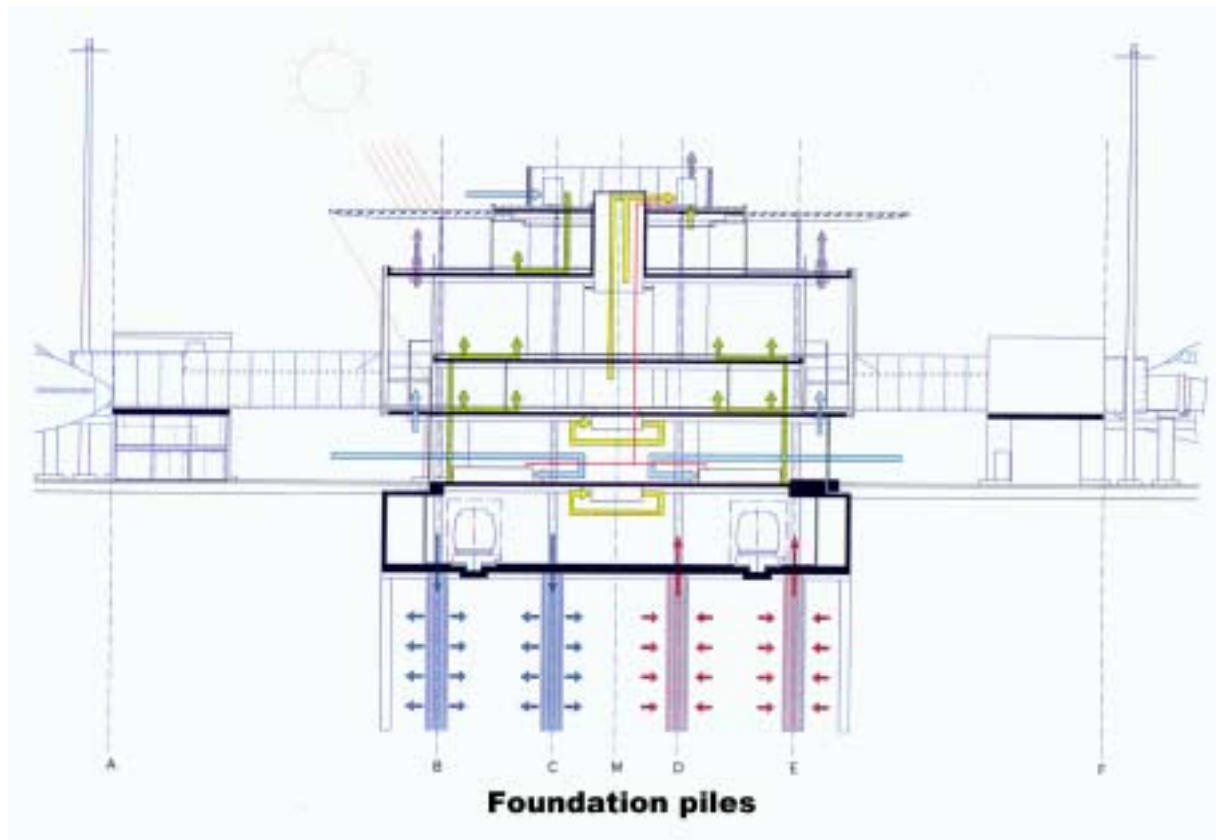

Fig. 1.1 Cross section of Dock Midfield.

### *1.2 Simulation Tools of Pile Systems*

The design of such a system requires a design tool which takes into account the thermal process in the piles and the ground. Both short term and long term effects have to be taken into account. Simulation tools of heat exchanger pile systems have been developed in the Laboratory of Energy Systems (LASSEN), at the Swiss Federal Institute of Technology in Lausanne (EPFL) (see FROMENTIN et al. 1997). Their development has been carried out with the help of measurements from existing systems for comparison and validation purposes. The well-known transient system simulation programme TRNSYS (KLEIN et al. 1998) was used. A non-standard simulation model, devised for heat storage in the ground with borehole heat exchangers (PAHUD et al. 1996a), has been adapted for heat exchanger piles (PAHUD et al. 1996b) and used to build up the simulation tools. However, the required level of knowledge limits their use to few experts in the field. Furthermore, the time required to adapt these simulation tools to a particular case make them unsuitable for a feasibility or pre-design study. Simple design rules were also established with the help of these simulation tools (FROMENTIN et al. 1997), but they are limited to special cases only.

### *1.3 Main Objectives*

There is a need for a design simulation tool for such systems which can be used by people who are not necessarily experts in system simulation, which do not require too much time to use it and which provides sufficient flexibility for a large variety of system concepts. The main objectives of this study are to:

- develop a simple design tool (PILESIM) for pre-design studies of heat exchanger pile systems;
- apply PILESIM to the Dock Midfield case for potential and optimisation assessments;
- optimise the pile system layout and system control with a detailed simulation of the system;
- provide to others the methodology used for the design process and history of the Dock Midfield pile system.

### *1.4 Historic of the Project*

The experience gained in the simulation of such systems was used to create PILESIM (PAHUD, 1999). The development of the simulation tools that were validated with measurements from existing systems (FROMENTIN et al. 1997) forms the basis of PILESIM. This programme offers easy use and relatively fast calculations. A short description of PILESIM is given in Appendix 1.

Early versions of PILESIM were used to assess the thermal potential offered by the piles and to optimise the size of the heat pump. The main information required by PILESIM concern the heating and cooling demand, the piles and the ground properties. With the evolution of the Dock Midfield project, the input data to PILESIM became more precise, and several calculations were performed to adapt the pile system to the last knowledge of the project. The heating and cooling requirements were assessed at different stages of the project. A first and rough estimate was based on the programme DIAS (1996) for the heating demand and the recommendation SIA 382/2 (1992) for the cooling demand. The final estimation of the heating and cooling requirement is the result of a TRNSYS simulation of the building (Koschenz and Weber, 1998) which gives the evolution for a typical year in hourly value. The

thermal properties of the ground were determined in situ with a “response test” performed on two boreholes drilled in the zone that will be crossed by the piles.

PILESIM does not require a precise knowledge of the system layout and assumes an ideal system control. The last calculation has been carried out with a detailed model of the pile system made with TRNSYS, so that the system layout and the system control were reproduced and simulated. Trials with the detailed simulation model helped to understand the system dynamic and to find a solution for a satisfactory system operation. They were useful to optimise the system layout and the system control. Hopefully they will be helpful for the startup and control setting of the system, and shorten the necessary time until an adequate system operation is reached. (With this kind of systems, it is common to make adjustment of the system control during 1 or 2 years before a satisfactory system operation is obtained).

### *1.5 Content of the Report*

A complete description of PILESIM is found in the PILESIM user manual. It is a separate report (see PAHUD (1999) for more details). In this report, only the simulation results of PILESIM applied to the Dock Midfield are shown.

Chapter 2 contains the ground properties used for the simulations. A complete description of the response tests performed for the determination in situ of the ground properties is found in (PAHUD et al., 1998).

Chapter 3 contains the main input data used for the simulations (heating and cooling demand, piles, ground properties) and shows how these data have changed with the evolution of the project.

Chapter 4 shows the simulation results obtained with PILESIM used with the most up to date inputs.

In chapter 5, the detailed simulation model has been used with the same input data as PILESIM. The results are presented in the same way as PILESIM for comparison purpose. A complete description of the system layout and system control is provided.



## 2. Ground Properties

The ground properties were determined in situ with two boreholes heat exchangers drilled to a depth of 33m, corresponding to the bottom of the future piles. One borehole lies in the east part of Dock Midfield and one in the west part. A response test has been performed on each of these boreholes (see PAHUD et al., 1998). The results of the response test analysis are the effective mean thermal conductivity of the ground along the borehole and the borehole thermal resistance. These two parameters determine the heat transfer between the fluid which circulate in the borehole and the surrounding ground. With an appropriate numerical model, these two parameters are used to recalculate the heat transfer from the borehole to the ground for any loading conditions.

For the Dock Midfield simulation, the mean effective thermal conductivity of the ground is the most important parameter to be known (this effective value would take into account an eventual ground water movement). A pessimist value has been estimated, based on the basis of uncertainties related to the main factors which determine its value (see PAHUD et al., 1998). The results of the analysis are summarised in table 2.1.

| Mean effective ground thermal conductivity | East borehole | West borehole |
|--|---------------|---------------|
| Estimated value                            | 2.08 W/mK     | 1.93 W/mK     |
| Pessimistic value                          | 1.88 W/mK     | 1.79 W/mK     |

Table 2.1 Estimation of the mean effective ground thermal conductivity in the East and West boreholes.

In the East borehole, the estimated thermal conductivity is slightly greater than that of the West borehole. The difference can be explained as follow: unlike the West borehole, the East borehole crosses a layer of water saturated gravel of 5.7 m thickness. If one assumes a thermal conductivity of 2.3 W/mK for this layer, which is realistic for saturated gravel, the mean thermal conductivity of the ground below this layer should have a value of 1.8 W/mK in the pessimist situation, so that the average value of 1.88 W/mK is preserved. This superficial gravel layer will be removed when the Dock Midfield will be constructed. In consequence, it is most likely that the thermal conductivity of the ground will be 1.8 W/mK, in agreement with the pessimist estimation of the West borehole. The pessimistic value is chosen for the numerical simulations, in order to obtain conservative results.

**Mean effective ground thermal conductivity used for the thermal simulations of the  
heat exchanger pile system: 1.8 W/mK**

The ground is mainly composed by clay and lake deposit (JÄCKLI, 1996). The estimated thermal conductivity is realistic. It also confirms the hydrogeological data which indicate that a regional movement of the ground water is likely to be very small.

### 3. Heating and Cooling Demand and Pile System Thermal Performances

As previously mentioned, the heating and cooling demand have been estimated at three different times, depending on the state of knowledge of the project. For each estimation, a thermal simulation of the pile system has been carried out. In this chapter, the three estimations of the heating and cooling demand are presented, together with some other important parameters used for the calculations (number of piles and ground thermal conductivity). The intention is to give a picture of the evolution of the project together with the results of the successive simulations.

#### 3.1 First Estimation of the Heating and Cooling Demand

The first estimation of the heating and cooling demand has been done early in the project, based on the programme DIAS (1996) and the recommendation SIA 382/2 (1992). The annual energy for heating is estimated to 3'000 MWh with a peak power of 2.5 MW. The heating energy is delivered at a relatively low temperature level, comprised between 40 to 45 °C. The annual cooling needs are estimated to 2'500 MWh with a peak power of 2.75 MW. The evolution of the heating and cooling demand are shown in figure 3.1.

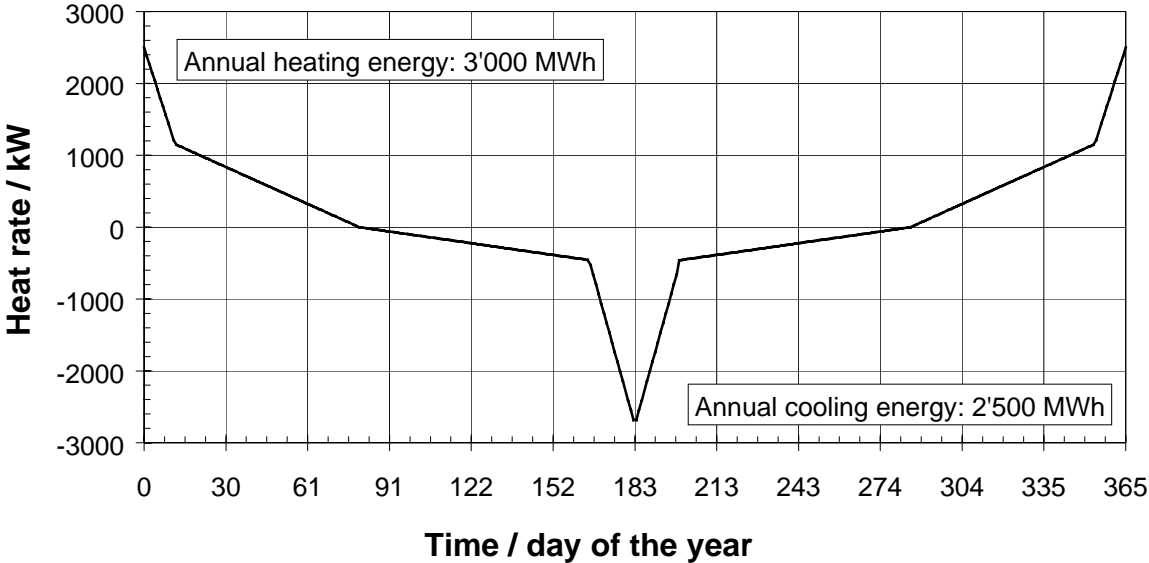

Fig. 3.1 First estimation of the heating and cooling demand for Dock Midfield.

The heat exchanger pile system provides part of the heating and cooling demand. The rest is covered by district heat and cooling units. The cooling energy provided by the piles is performed in “direct cooling” mode, i.e. the pile flow circuit is connected to the cold distribution without a cooling machine in between. The pile system was supposed to deliver 500 kW at the heat pump condenser (1'560 MWh/year) and satisfy 400 kW of the cooling requirements (1'250 MWh/year).

The first simulations of the system have been performed with 196 piles of 25 m long. The thermal conductivity of the ground was not yet measured and a value of 2 W/mK was assumed, based on the types of ground found in the geological investigations (JÄCKLI, 1996).

The main purposes of the first simulations were to check if the expected thermal performances were realistic and to assess the impact of using pure water in the pile flow circuit on the system thermal performances. The constraint on the system are imposed by the fluid temperature in the piles, which may only vary between -1 °C and 18 °C when antifreeze is used, and between 4 °C and 18 °C when pure water is used. With antifreeze, the minimum temperature is set so that the concrete in the pile never freezes. It can be set to -1 °C, due to the thermal resistances of the convective heat transfer in the pipes and the plastic pipes themselves. These temperature constraints determine the maximum powers that can be extracted or injected in the piles. The results of the first simulation are summarised in table 3.1.

| Thermal performances of the pile system         | Heating                  | Cooling                |
|---|--------------------------|------------------------|
| Pure water used (fluid temperature 4°C - 18°C)  | 200 kW<br>710 MWh/year   | 110 kW<br>490 MWh/year |
| With antifreeze (fluid temperature -1°C - 18°C) | 360 kW<br>1'200 MWh/year | 150 kW<br>640 MWh/year |

Table 3.1 Thermal performances of the pile system based on the first estimation of the heating and cooling requirements. The thermal conductivity of the ground was assumed to be 2 W/mK and 196 piles were used.

The first simulations showed that the expected thermal performances of the pile system were too optimistic. They also showed that using pure water significantly limited the heating potential of the piles. However the heating and cooling demand occur during two different periods of the year, which excludes the situation where the heat pump extract heat from the cooling distribution for heating purposes. This first estimation of the heating and cooling demand leads to a disadvantageous situation for the pile system.

### 3.2 *Second Estimation of the Heating and Cooling Demand*

The second estimation of the heating and cooling demand has been carried out with TRNSYS by the EMPA (KOSCHENZ and WEBER, 1997), at an early phase of the project. The annual energy for heating is estimated to 1'280 MWh with a peak power of 2.8 MW. The heating energy is still delivered at a relatively low temperature level, comprised between 40 to 45 °C. The cooling needs are split in different part. The annual cooling energy that should be covered by the pile system is estimated to 620 MWh, with a peak power of 0.5 MW. The evolution of the heating and cooling demand are shown in figure 3.2.

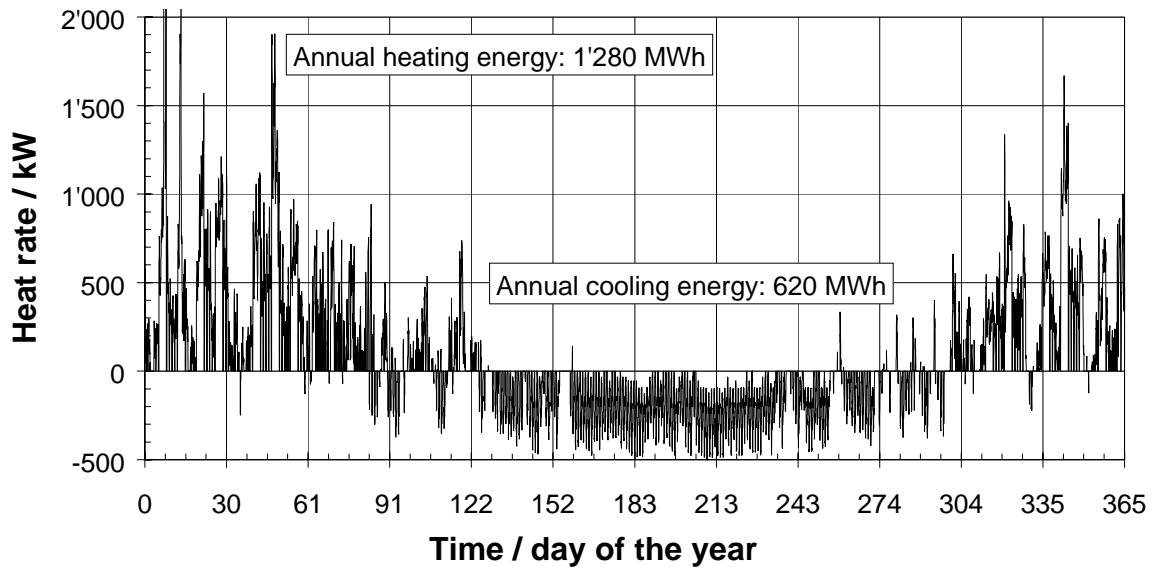

Fig. 3.2 Second estimation of the heating and cooling demand for Dock Midfield.

The second simulation set of the system has been performed with 200 and 304 piles of 25 m long. The thermal conductivity of the ground was not yet measured. The assumed value of 2 W/mK was used for the ground.

The main purposes of the second set of simulations were to recalculate the thermal performances of the pile system with the last estimation of the heating and cooling requirements. As the number of foundation piles was increased, the influence of additional piles was also assessed on the system thermal performances. The fluid temperature in the piles may now vary between 0 °C and 20 °C (antifreeze is used). These temperature constraints, together with the evolution of the heating and cooling energy demand, determine the maximum powers that can be extracted or injected in the piles. The power of the heat pump can be decreased to meet the temperature constraint. The heat pump power is sized so that a power decrease of maximum 10% is allowed. The results of the simulations are summarised in table 3.2.

| Thermal performances of the pile system | Heating                  | Cooling                      |
|---|--------------------------|------------------------------|
| 200 heat exchanger piles are used       | 600 kW<br>710 MWh/year   | 210 - 450 kW<br>580 MWh/year |
| 304 heat exchanger piles are used       | 800 kW<br>1'150 MWh/year | 360 - 470 kW<br>610 MWh/year |

Table 3.2 Thermal performances of the pile system based on the second estimation of the heating and cooling requirements. The thermal conductivity of the ground was assumed to be 2 W/mK.

When all the piles are used, nearly the totality of the cooling demand can be satisfied with the piles in “direct cooling” mode.

### 3.3 Third Estimation of the Heating and Cooling Demand

The third and last estimation of the heating and cooling demand has also been carried out with TRNSYS by the EMPA (KOSCHENZ and WEBER, 1998), on the basis of the last information available in Spring 1999 (about 1 year after the previous estimation). The annual energy for heating is estimated to 2'720 MWh with a peak power of 4.0 MW. The heating energy is still delivered at a relatively low temperature level, comprised between 40 to 45 °C. The cooling needs are split in different part. The annual cooling energy that should be covered by the pile system is estimated to 1'240 MWh, with a peak power of 0.5 MW. The evolution of the heating and cooling demand are shown in figure 3.3.

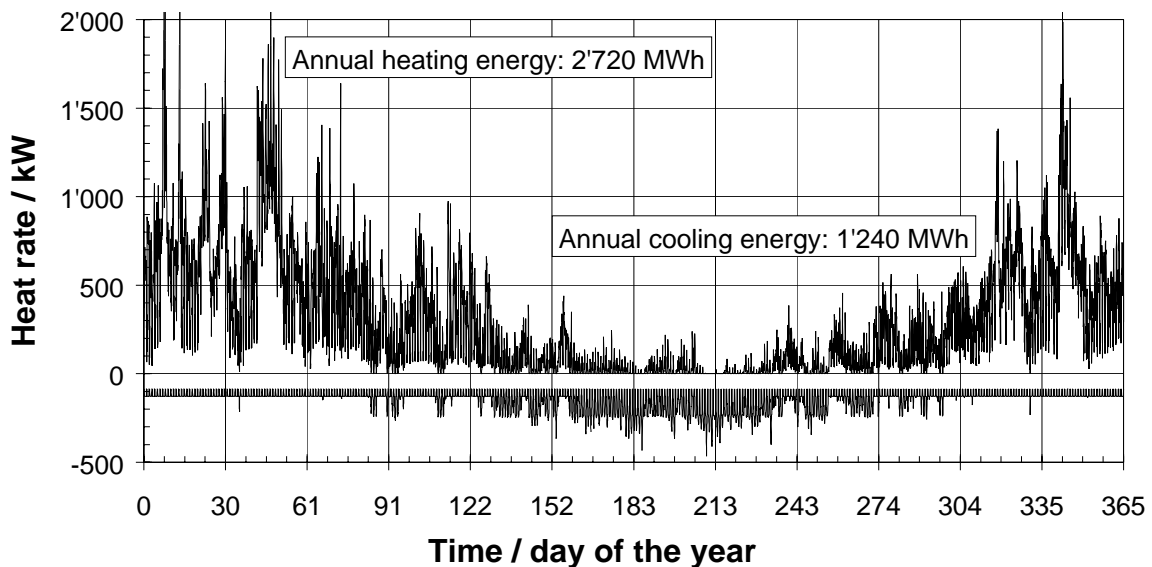

Fig. 3.3 Third and last estimation of the heating and cooling demand for Dock Midfield.

The third and last simulation set of the system has been performed with 306 piles of 26.8 m long in average. The thermal conductivity of the ground obtained with the response test was used (1.8 W/mK).

The main purposes of the third set of simulations were to recalculate the thermal performances of the pile system with the last estimation of the heating and cooling requirements. The finalised version of PILESIM was used to assess the system thermal performances (see chapter 4). A detailed model of the system was also used (see chapter 5), in order to improve the calculation of the system thermal performances and to find out an optimum solution for the system layout and system control. The results of the simulations are summarised in table 3.3.

| Thermal performances of the pile system | Heating                  | Cooling                       |
|---|--------------------------|-------------------------------|
| PILESIM                                 | 630 kW<br>2'300 MWh/year | max. 400 kW<br>1'080 MWh/year |
| Detailed model of the pile system       | 630 kW<br>2'300 MWh/year | max. 330 kW<br>1'160 MWh/year |

Table 3.3 Thermal performances of the pile system based on the third and last estimation of the heating and cooling requirements. The thermal conductivity of the ground was measured to 1.8 W/mK and 306 piles were used.

Unlike to the previous estimations of the heating and cooling demand, the constant cooling requirement of about 90 kW improves the pile system thermal performances, as the heat pump extracts heat from the cold distribution for heating purposes.

The cooling energy calculated with PILESIM is as expected lower (-7%) than the cooling energy calculated with the detailed model. In PILESIM, the flow rate through the piles is constant, whereas in the actual system (and in the detailed model), a variable flow rate is used to adjust the temperature level of the fluid to the required temperature level of the cooling distribution (14°C). In PILESIM, the cooling energy rate satisfied by the piles is also more irregular with a constant flow rate, and this leads to a higher peak cooling rate (see in table 3.3).

## 4. The PILESIM Simulation of Dock Midfield

The PILESIM simulation has been performed with the last information available in Spring 1999. In section 4.1 the main input parameters are listed. The simulation results are shown in section 4.2.

### 4.1 Main Input Parameters for PILESIM

The chosen system simulated with PILESIM is *heating with direct cooling only*, in order to assess the fraction of the cooling energy demand that is covered by direct cooling. A short description of PILESIM is found in appendix 1. The rest of the cooling demand is still covered by the pile system in reality, with the heat pump used as a cooling machine. The waste heat is dumped in the outside air through cooling towers.

PILESIM assumes a constant flow rate through the heat exchanger piles which is the same for heat extraction (heating mode) and heat injection (cooling mode). In the actual system, this is not the case: in the cooling mode, the return fluid temperature in the piles is 20 °C and 12 °C for the forward fluid temperature, giving a temperature drop of 8 K. The temperature of 12 °C is required by the cooling distribution system to ensure a proper operation. It clearly means that the flow rate through the piles is variable, in order to adjust the outlet fluid temperature from the piles to the desired one. In the heating mode, the temperature drop through the piles is 4 K. In PILESIM, this problem is solved by assigning a temperature drop of 8 K in the heat pump evaporator. It means that the minimum fluid temperature in the piles is -2 °C in PILESIM, which corresponds to about 0 °C in the actual system. PILESIM calculated a constant flow rate through the piles called FLOWPIL, which is then used for the simulation of the heat rate injected through the piles in the direct cooling mode. (FLOWPIL is calculated by PILESIM from the input parameters, and is written in the PILESIM.OPA output file). The hourly heat rate injected in the piles, as calculated in PILESIM, is expressed by relation (4.1).

$$P_{\text{directcool}} = C \text{ FLOWPIL} (T_{\text{inpile}} - T_{\text{outpile}}) \quad (4.1)$$

Where:

$P_{\text{directcool}}$ : heat rate injected through the piles by direct cooling (kW);

C: heat capacity of the fluid (3.8 kJ/kgK);

FLOWPIL: flow rate through the pile that is used by PILESIM, determined from the heat pump design heat powers and design inlet - outlet temperature drop in the evaporator (kg/s);

$T_{\text{inpile}}$ : inlet fluid temperature in the piles (°C);

$T_{\text{outpile}}$ : outlet fluid temperature from the piles, which has to be 12 °C.

The heat rate  $P_{\text{directcool}}$  is obtained with relation (4.2), by assuming that the totality of the cooling demand is satisfied by direct cooling and the heat rate extracted at the evaporator for heating purpose:

$$P_{\text{directcool}} = P_{\text{cold}} - P_{\text{heatevap}} \quad (4.2)$$

Where:

$P_{\text{cold}}$ : hourly cold energy demand (kW);

$P_{\text{heatevap}}$ : hourly heat rate extracted by the heat pump for heating purpose (kW);

The heat rate extracted by the heat pump is obtained with relation (4.3):

$$P_{\text{heatevap}} = P_{\text{heat}} (\text{COP} - 1)/\text{COP} \quad (4.3)$$

Where:

$P_{\text{heat}}$ : hourly heat demand covered by the heat pump (kW);

COP: performance coefficient of the heat pump, assumed to be constant (-).

In PILESIM and for the direct cooling mode, the inlet fluid temperature in the piles is given as input data to the programme. It is known from the temperature level of the forward fluid to the cold distribution and the design temperature difference defined at the evaporator, set in this case to 8 K (see relation 4.4).

$$T_{\text{inpile}} = T'_{\text{pileout}} + \Delta T \quad (4.4)$$

Where:

$\Delta T$ : design temperature drop of the fluid circulating in the piles, set to 8 K.

$T'_{\text{pileout}}$ : temperature level of the forward fluid to the cold distribution, which is an input to PILESIM.

The heat rate injected through the piles is then calculated with  $T_{\text{inpile}}$  and FLOWPIL. If it exceeds the maximum possible value ( $P_{\text{directcool}}$ ) obtained with relation (4.2), the inlet fluid temperature  $T_{\text{inpile}}$  is decreased until the calculated heat injection rate equals  $P_{\text{directcool}}$ .

It should be noticed that the outlet fluid temperature  $T_{\text{outpile}}$  is not necessarily equal to  $T'_{\text{pileout}}$ , as the inlet - outlet temperature difference is not necessarily equal to  $\Delta T = 8$  K. This latter depends on the flow rate, constant in PILESIM, and the heat rate injected through the piles  $P_{\text{directcool}}$ , which varies with the time. When the direct cooling requirement is small, the outlet fluid temperature  $T_{\text{outpile}}$  will be greater than  $T'_{\text{pileout}}$ , the desired temperature level of the forward fluid to the cooling distribution. In consequence,  $T'_{\text{pileout}}$  has to be adjusted for each value of the cooling heat demand, so that the calculated outlet fluid temperature from the piles ( $T_{\text{outpile}}$ ), assuming that the totality of the cooling demand is satisfied, is equal to 12 °C. The temperature level of the forward fluid to the cooling distribution, given as an input to PILESIM, has a fictive value obtained by combining (4.1) and (4.4):

$$T'_{\text{pileout}} = T_{\text{outpile}} + P_{\text{directcool}} / (C \text{ FLOWPIL}) - \Delta T \quad (4.5)$$



Where:

$T_{\text{outpile}}$ : actual forward fluid temperature to the cold energy distribution, set to 12 °C;  
 $P_{\text{directcool}}$ : is obtained with equations (4.2) and (4.3);  
 $C$ : heat capacity of the fluid (3.8 kJ/kgK);  
FLOWPIL: constant flow rate through the pile, as simulated with PILESIM (kg/s);  
 $\Delta T$ : temperature drop of the fluid circulating in the piles, set to 8 K.

#### Heat Pump and Cooling Machine Parameters

|   |     |    |
|---|-----|----|
| Design electric power of the heat pump:                   | 140 | kW |
| Design performance coefficient (COP):                     | 4.5 | -  |
| Constant COP and efficiency during simulation:            | Yes |    |
| Design inlet-outlet temperature difference in evaporator: | 8   | K  |

#### Interface Ground-Building Parameters

|   |               |    |
|---|---------------|----|
| Room air temperature in the cellar above the ground:        | 20            | °C |
| Insulation between cellar and ground:                       | no insulation |    |
| Concrete thickness between ground and cellar:               | 0.6           | m  |
| Length of the horizontal connecting pipes below the cellar: | 1'380         | m  |

#### Heat Exchanger Pile Parameters

The number of heat exchanger piles has been decreased by 3% to take into account the number of heat exchanger piles that will be damaged when they are built.

|   |      |         |
|---|------|---------|
| Diameter of pile type 1:                  | 0.9  | m       |
| Number of piles for type 1:               | 60   | -       |
| Average active length of piles type 1:    | 26.2 | m       |
| Thermal resistance of pile type 1:        | 0.06 | K/(W/m) |
| Diameter of pile type 2:                  | 1.2  | m       |
| Number of piles for type 2:               | 18   | -       |
| Average active length of piles type 2:    | 27.2 | m       |
| Thermal resistance of pile type 2:        | 0.06 | K/(W/m) |
| Diameter of pile type 3:                  | 1.3  | m       |
| Number of piles for type 3:               | 49   | -       |
| Average active length of piles type 3:    | 25.8 | m       |
| Thermal resistance of pile type 3:        | 0.06 | K/(W/m) |
| Diameter of pile type 4:                  | 1.5  | m       |
| Number of piles for type 4:               | 179  | -       |
| Average active length of piles type 4:    | 27.2 | m       |
| Thermal resistance of pile type 4:        | 0.06 | K/(W/m) |
| Average spacing between the piles:        | 9    | m       |
| Pipe number in a cross section of a pile: | 10   | -       |

|  |    |    |
|--|----|----|
| Inner diameter of one pipe:                                    | 16 | mm |
| Fraction of pile concrete thermal capacity taken into account: | 50 | %  |

#### Ground Characteristics

|  |                               |                     |
|--|-------------------------------|---------------------|
| Initial ground temperature:            | 10.3                          | °C                  |
| Thermal conductivity of ground:        | 1.8                           | W/mK                |
| Volumetric thermal capacity of ground: | 2200                          | MJ/m <sup>3</sup> K |
| Darcy velocity of ground water:        | no regional ground water flow |                     |

#### 4.2 Output Results Obtained with PILESIM

The simulation is performed for 10 years in order to take into account long term effects (annual heat extraction not equal to the annual heat injection through the piles, thermal influence of the building). The temperature evolution of the inlet and outlet fluid temperature in the piles is shown for the 10<sup>th</sup> operation year in figure 4.1.

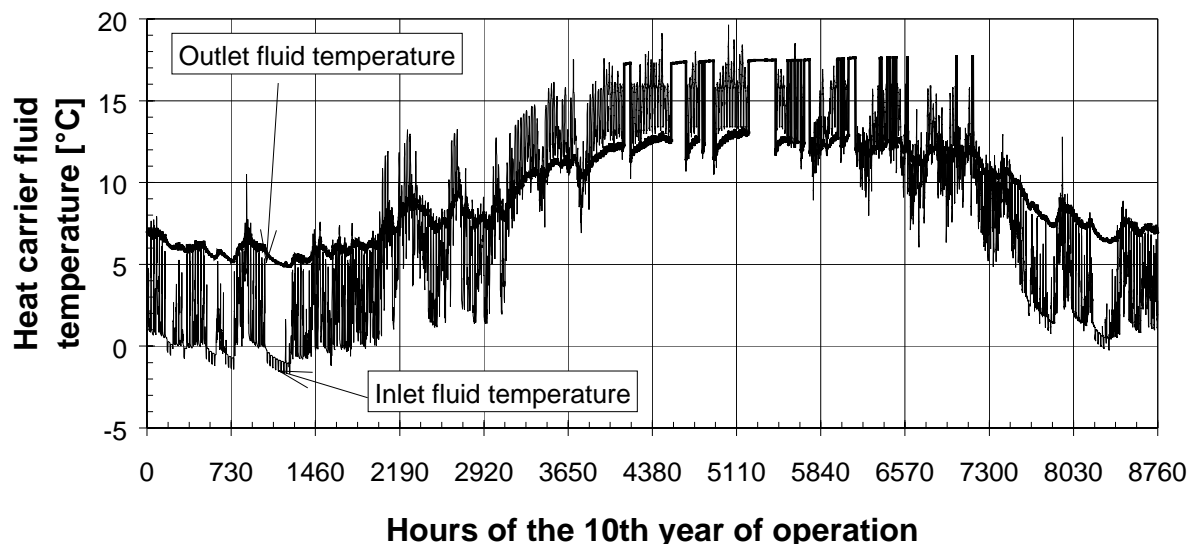

Fig. 4.1 Temperature evolution of the inlet and outlet fluid temperature in the piles for the 10<sup>th</sup> year of operation, simulated with PILESIM. The inlet - outlet temperature difference during winter is set to 8 K at design conditions, so that the design flow rate is not too large for direct cooling.

The maximum heating power of the heat pump, assuming a constant performance coefficient of 4.5, is fixed to 630 kW. The power never needs to be reduced to prevent the fluid temperature in the piles from being too low, as the cooling demand is never zero all over the year (see fig. 3.3). As a result, the maximum heat rate extracted on the piles is always decreased by the minimum cooling rate. The annual heat energy extracted from the piles is 1'110 MWh/year, whereas only 400 MWh/year are injected back in the ground through direct cooling. However, the average ground temperature in the pile region is not significantly varying after 10 years of operations, due to the heat losses of the building in the ground, which are estimated to 760 MWh/year when the average temperature of the rooms in contact with the

ground is assumed to be 20 °C. In figure 4.2 and 4.3, the diagrams shows the annual energy fluxes through the pile system and the heat exchanger piles.

### GLOBAL SYSTEM HEAT BALANCE

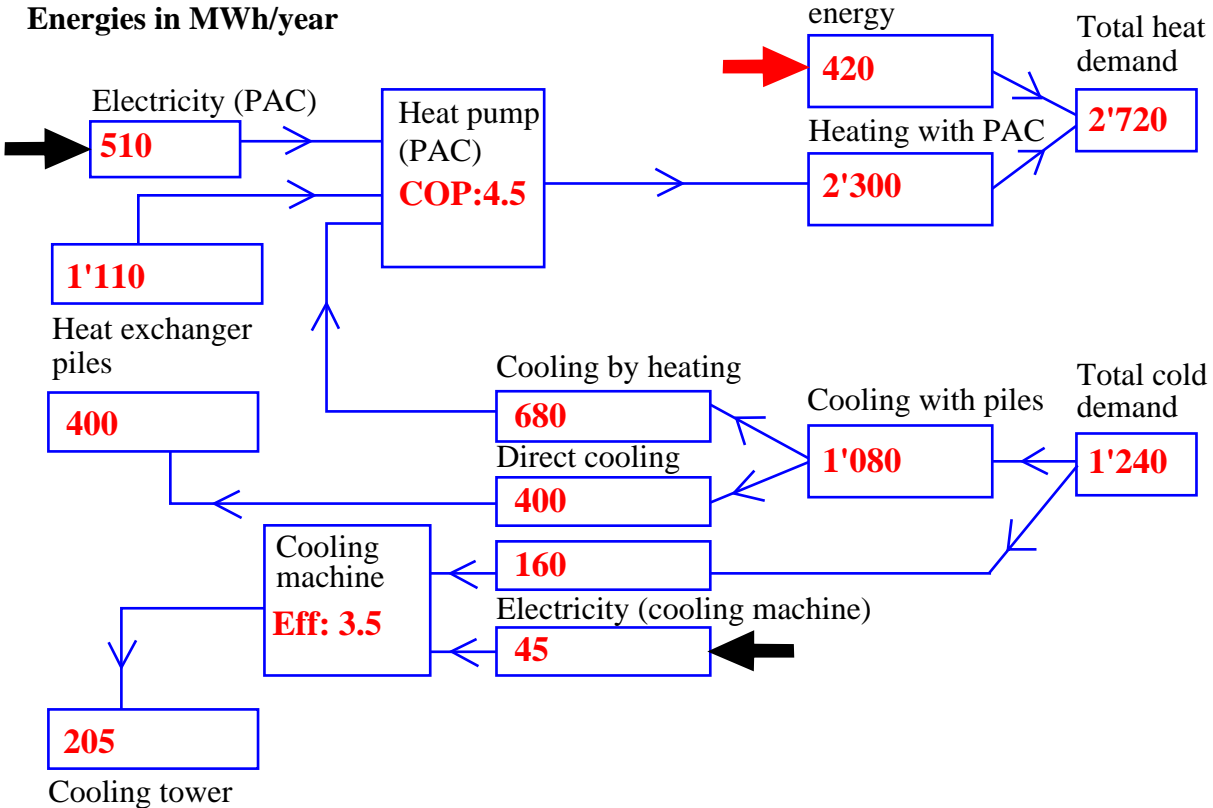

Fig. 4.2 Annual energy fluxes through the pile system, average values for the first 10 years of operation (simulated with PILESIM).

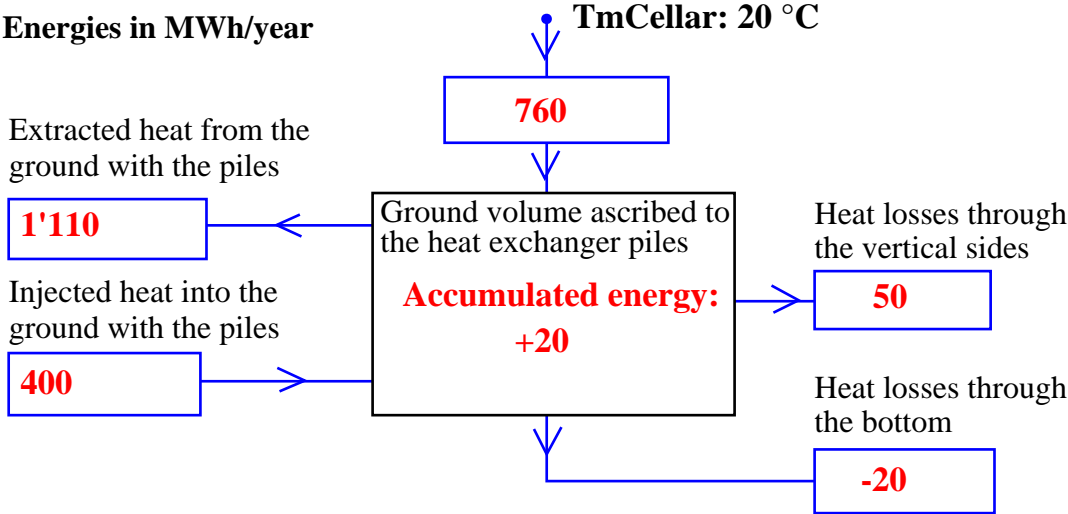

Fig. 4.3 Annual energy fluxes through the heat exchanger piles, average values for the first 10 years of operation (simulated with PILESIM).

The heat pump connected to the piles covers 85% of the total heat demand. The fraction of the cooling energy demand covered by direct cooling and the cooling energy used for heating purpose represent 87%. The remaining cooling demand has to be covered by the heat pump used as a cooling machine, with a maximum of 330 kW of cooling power for the 10<sup>th</sup> year of operation.

The total active length of heat exchanger piles is about 8'200 m. The heat rate and annual energies extracted and injected through the piles are, per unit length of heat exchanger piles:

**PILESIM simulation:**

**Heating:**                **49**        **W/m**                                **135**        **kWh/m year**  
**Cooling:**                **49**        **W/m**                                **48**        **kWh/m year**

The influence of some parameters on the direct cooling energy is also assessed. The simulation with the default values of the parameters represent the case 0. Only one parameter is varied at a time, all the other ones have their default value. The varied parameters are:

- case 1: temperature of the cellar set to 18 °C instead of 20 °C.
- case 2: length of the horizontal pipe connections set to 3'000 m instead of 1'380 m.
- case 3: average spacing of the piles set to 8.5 m instead of 9.0 m.
- case 4: initial temperature of the ground set to 11.0 °C instead of 10.3 °C.

The extracted energy from the ground is the same for all the cases; (a constant performance coefficient for the heat pump is assumed and the fluid temperature in the piles is always greater than the minimum tolerated one). The results are summarised in table 4.1:

| Energies in MWh/year                  | Cooling with heat pump | Direct cooling | Cooling with cooling machine | Building losses to ground |
|---------------------------------------|------------------------|----------------|------------------------------|---------------------------|
| Case 0 (default)                      | 680                    | 400            | 160                          | 760                       |
| Case 1 (T <sub>cel</sub> : 18°C)      | 680                    | 490            | 70                           | 640                       |
| Case 2 (L <sub>con</sub> : 3'000 m)   | 680                    | 340            | 220                          | 840                       |
| Case 3 (L <sub>spacing</sub> : 8.5 m) | 680                    | 420            | 140                          | 720                       |
| Case 4 (T <sub>ground</sub> : 11°C)   | 680                    | 370            | 190                          | 740                       |

Table 4.1: Influence of several parameters on the cooling energy provided by the heat pump, direct cooling on the piles and the remaining cooling energy provided by the cooling machine. The heat losses of the building through the ground are also shown. The annual energy values are averages during the first 10 years of operation and were calculated with PILESIM.

The fraction of the cooling demand covered by the heat pump and direct cooling varies between 80 to 95%. The temperature of the cellar and the heat transfer capacity of the horizontal pipe connections have a strong influence on the cooling energy provided by direct cooling. The greater these parameter are, the lower the direct cooling energy is. However, a lower value of the direct cooling energy is more or less compensated by greater heat losses of the building through the ground. The average ground temperature does not significantly changes after 10 years of operation, which indicates that the risk of freezing the piles is not increasing from year to year.

## 5. Detailed Simulation Model of the System

In this chapter, a detailed simulation model of the pile system developed with TRNSYS is presented. The main purposes are to check and improve the results obtained with PILESIM, understand the system dynamic and establish an optimal system control on the basis of the proposed system layout. Very detailed information on the system dynamic were gathered. A simulation time-step of 45 seconds is used and 10 years of system operation is simulated.

### 5.1 System Layout

The analyses have lead to a slightly different system layout from the original one. A schematic view of this system layout is shown in figure 5.1. Note that in the real system, the position of the 3-way valves would be either at a different place or replaced with two 2-way valves, depending on technical and practical reasons (see HUBBUCH 1999 for the actual positions of the valves). However, the system concept and operation remain unchanged.

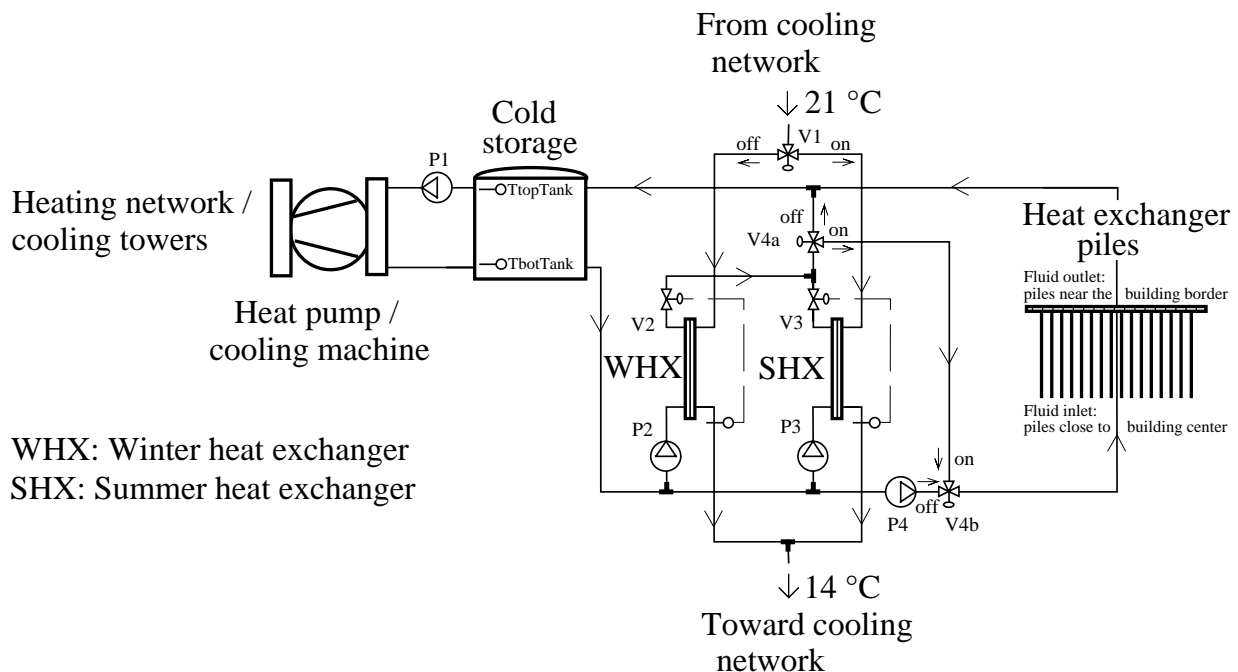

Fig. 5.1 Schematic layout of the Dock Midfield heat exchanger pile system. This system layout is chosen as a reference for the TRNSYS simulations.

The circulation of the fluid in the piles is always in the same direction. The direction is chosen so that it is best for the “direct cooling” mode. During this mode, the pump P4 is stopped and the three-way valves are set to let the fluid flow from valve V4a to V4b. The piles are coupled together by series of three. The fluid enters in the piles which are located in the inner part of the building and flows toward the piles located at the side of the building. An alternative to the system layout shown in figure 5.1 would make the fluid circulate in the opposite direction when heat is extracted from the piles. This alternative is shown in figure 5.2. Note the permutation of the building border and centre in the drawing. However, a simulation has shown that the improvement of the thermal performances are only slightly better. The direct cooling energy is increased by 0.4%. The system layout shown in figure 5.2

is to be preferred to the system layout shown in figure 5.1 only if it does not add practical or technical problems.

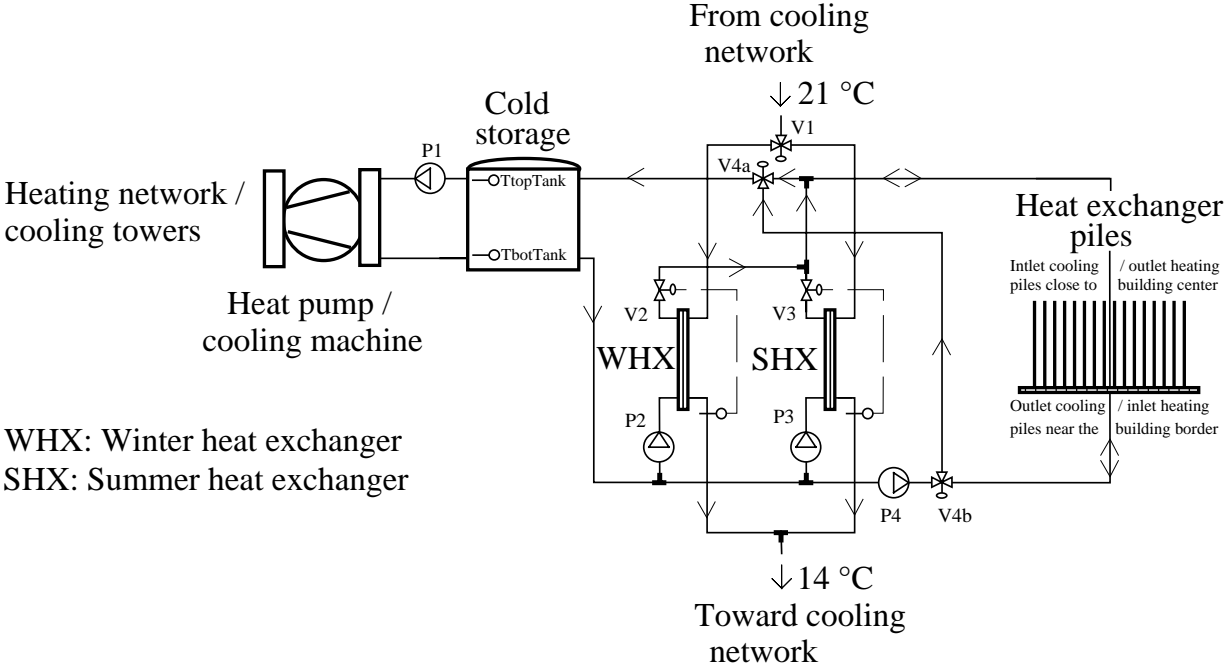

Fig. 5.2 Alternative to the system layout shown in figure 5.1. The fluid circulation is reversed when heat is extracted from the piles.

Before the operational modes and the system control are described, the size and operation of the two heat exchangers (WHX and SHX) are discussed.

5.2 The Winter and Summer Heat Exchangers

The cooling demand that must be satisfied by the heat exchanger pile system may range from 90 kW to 700 kW. On the side of the cooling distribution, the return fluid temperature is supposed to be 21 °C and the forward one has to be 14 °C. This temperature is controlled by the two-way valve on the primary side of the heat exchanger, which adjusts the flow rate in the primary side to the right value. The heat exchanger is sized for an inlet fluid temperature of 12 °C in the primary side and the maximum heat rate to be transferred. As the inlet fluid temperature and the heat rate can be much lower than the design values, the flow rate has to be reduced to a very low value. For practical and technical reasons, two heat exchangers are used. One for low heat rates and fluid temperatures, the WHX (Winter Heat Exchanger), and one for large heat rates and greater fluid temperature, the SHX (Summer Heat Exchanger). Either the WHX or the SHX is used at a time. It should be noted that the WHX may also be used during the Summer. The idea is to prevent the flow rate in the heat exchanger primary side from being too small. The heat exchangers are sized as follow:

Summer heat exchanger (SHX)  
Maximum heat rate to be transferred: 700 kW

|                                  |       |                                  |       |
|----------------------------------|-------|----------------------------------|-------|
| Primary side:                    |       | Secondary side:                  |       |
| Design inlet fluid temperature:  | 12 °C | Design inlet fluid temperature:  | 21 °C |
| Design outlet fluid temperature: | 20 °C | Design outlet fluid temperature: | 14 °C |

These values define a nominal flow rate in the primary side of about 80 m<sup>3</sup>/h with relation (5.1).

$$P = C q (T_{po} - T_{pi}) \quad (5.1)$$

P : heat rate transferred by the heat exchanger (e.g. 700 kW);  
 T<sub>pi</sub> : inlet fluid temperature in the primary side of the heat exchanger (e.g. 12 °C);  
 T<sub>po</sub> : outlet fluid temperature from the primary side of the heat exchanger (e.g. 20 °C);  
 C : heat capacity of the fluid in the primary side of the heat exchanger (e.g. 4'000 kJ/m<sup>3</sup>K);  
 q : fluid flow rate in the primary side of the heat exchanger (m<sup>3</sup>/s).

The logarithmic mean temperature difference (LMTD) of the heat exchanger for these design conditions is calculated to -1.44 K with relation (5.2).

$$LMTD = ( (T_{pi} - T_{so}) - (T_{po} - T_{si}) ) / \ln( (T_{pi} - T_{so}) / (T_{po} - T_{si}) ) \quad (5.2)$$

LMTD : logarithmic mean temperature difference through the heat exchanger (K);  
 T<sub>pi</sub> : inlet fluid temperature in the primary side of the heat exchanger (°C);  
 T<sub>po</sub> : outlet fluid temperature from the primary side of the heat exchanger (°C);  
 T<sub>si</sub> : inlet fluid temperature in the secondary side of the heat exchanger (°C);  
 T<sub>so</sub> : outlet fluid temperature from the secondary side of the heat exchanger (°C).

The sign of the temperature difference is negative in the cooling situation as the thermal energy flows from the secondary side to the primary side of the heat exchanger. In other terms, the value of the heat rate transferred by the heat exchanger is negative, as the heat exchanger is used to extract heat from the cooling demand, set arbitrary to the secondary side of the heat exchanger. The overall heat transfer coefficient UA is obtained from LMTD and the heat rate transferred (cf. relation 5.3).

$$P = UA LMTD \quad (5.3)$$

P : heat rate transferred by the heat exchanger (kW);  
 LMTD : logarithmic mean temperature difference through the heat exchanger (K);  
 UA : overall heat transfer coefficient of the heat exchanger (kW/K).

The UA value is found to be 490 kW/K. A security factor of 25% in the size of the heat exchanger gives finally a UA value of 610 kW/K. The main thermal characteristics of the SHX are shown in table 5.1.

| Summer heat exchanger (SHX)                             |   |
|---|---|
| Design heat rate to be transferred                      | 700 kW  |
| Design inlet / outlet fluid temperature<br>primary side | T <sub>pi</sub> : 12 °C / T <sub>po</sub> : 20 °C |
| secondary side  | T <sub>si</sub> : 21 °C / T <sub>so</sub> : 14 °C |
| Nominal fluid flow rate in primary side                 | 80 m <sup>3</sup> /h                              |
| Design UA value   | 610 kW/K  |

Table 5.1 Design values of the summer heat exchanger (SHX)

Winter heat exchanger (WHX)

Maximum heat rate to be transferred: 200 kW

Primary side:

Design inlet fluid temperature: 4 °C

Design outlet fluid temperature: 12 °C

Secondary side:

Design inlet fluid temperature: 21 °C

Design outlet fluid temperature: 14 °C

The same considerations as for the SHX are applied to the WHX. The main thermal characteristics of the WHX are shown in table 5.2.

| Winter heat exchanger (WHX)                             |   |
|---|---|
| Design heat rate to be transferred                      | 200 kW  |
| Design inlet / outlet fluid temperature<br>primary side | T <sub>pi</sub> : 4 °C / T <sub>po</sub> : 12 °C  |
| secondary side  | T <sub>si</sub> : 21 °C / T <sub>so</sub> : 14 °C |
| Nominal fluid flow rate in primary side                 | 23 m <sup>3</sup> /h                              |
| Design UA value   | 26 kW/K   |

Table 5.2 Design values of the winter heat exchanger (WHX)

Choice between the SHX and the WHX

As previously said, one heat exchanger is used at a time. In the view of not having a too small flow rate in the primary side of the heat exchangers, the summer heat exchanger should be used only if the winter heat exchanger can not transfer the totality of the cooling demand. The winter heat exchanger is sized to transfer 200 kW when the inlet fluid temperature in the primary side is 4 °C. If this latter is smaller, the maximum heat rate that can be transferred is larger. Inversely, a greater inlet fluid temperature leads to a smaller heat transfer rate. For a given inlet fluid temperature and the flow rate obtained at design conditions, the corresponding maximum heat rate is calculated with the help of the relations 5.1 to 5.3. The relation between the fluid temperature and the heat rate transferred is shown in figure 5.3.

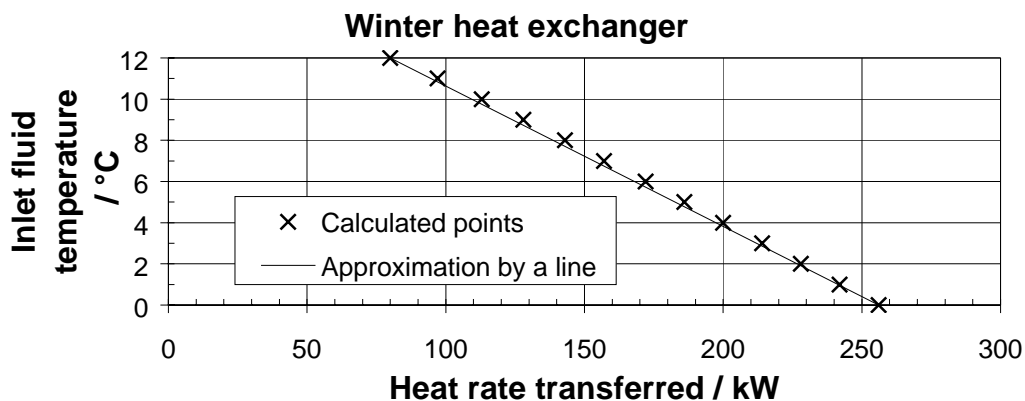

Fig. 5.3 Relation between the inlet fluid temperature in the primary side of the winter heat exchanger and the maximum heat rate that can be transferred.



The line drawn in figure 5.3 is the criterion used to select between the WHX and the SHX. It requests the knowledge of the cooling demand (or the measurement of the return fluid temperature and flow rate from the cooling distribution).

5.3 The System Operational Modes

Three different operational modes are defined. They are independent from the use of the WHX or the SHX. They are:

- pile cooling mode;
- pile resting mode;
- pile heating mode.

For each of these modes, the pile system can supply energy to both the heating and the cooling distributions. One exception is the use of the cooling machine, which may occur in the “pile cooling mode” only. In this case the heat from the machine condenser is dumped outside by the means of cooling towers, and can not be delivered to the heating network. However, the needs for heating are likely to be small when the cooling machine is used. When the “pile cooling mode” is active, direct cooling is performed. In figure 5.4, the drawing shows the setting of the pumps and valves for this mode. The cooling demand is arbitrary met through the winter heat exchanger (WHX). The heat pump is used as a cooling machine only if the piles can not meet the totality of the cooling demand.

**Pile cooling mode**

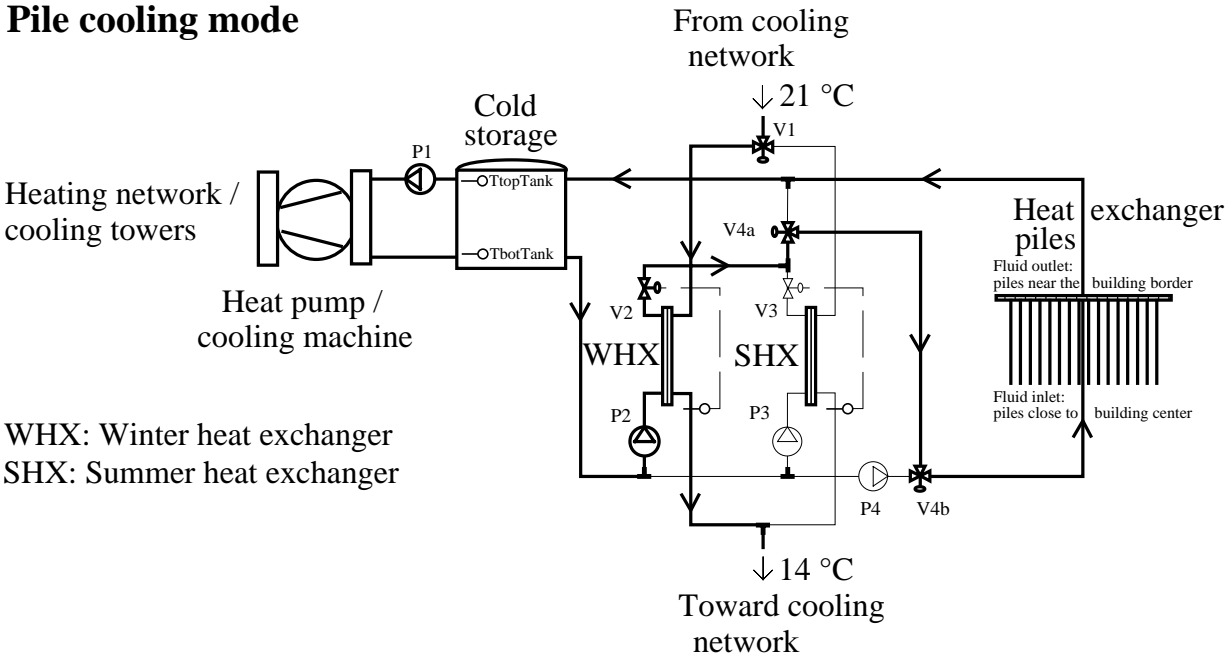

Fig. 5.4 Pile cooling mode: the pile pump P4 is stopped and the fluid flows toward the piles through the three-way valves V4a and V4b. The fluid is heated by the cooling demand and then cooled by the heat exchanger piles.

The maximum fluid temperature at the bottom of the cold storage is 12 °C in order to ensure a normal operation of the summer heat exchanger. If the fluid temperature rises above this limit, the cooling machine is used and stops a possible operation of the heat pump. If the fluid temperature decreases below a given threshold, the heat exchanger piles do not need to be used. In this case the operational mode switches from the “pile cooling mode” to the “pile resting mode”. The “pile resting mode” is shown in figure 5.5.

**Pile resting mode**

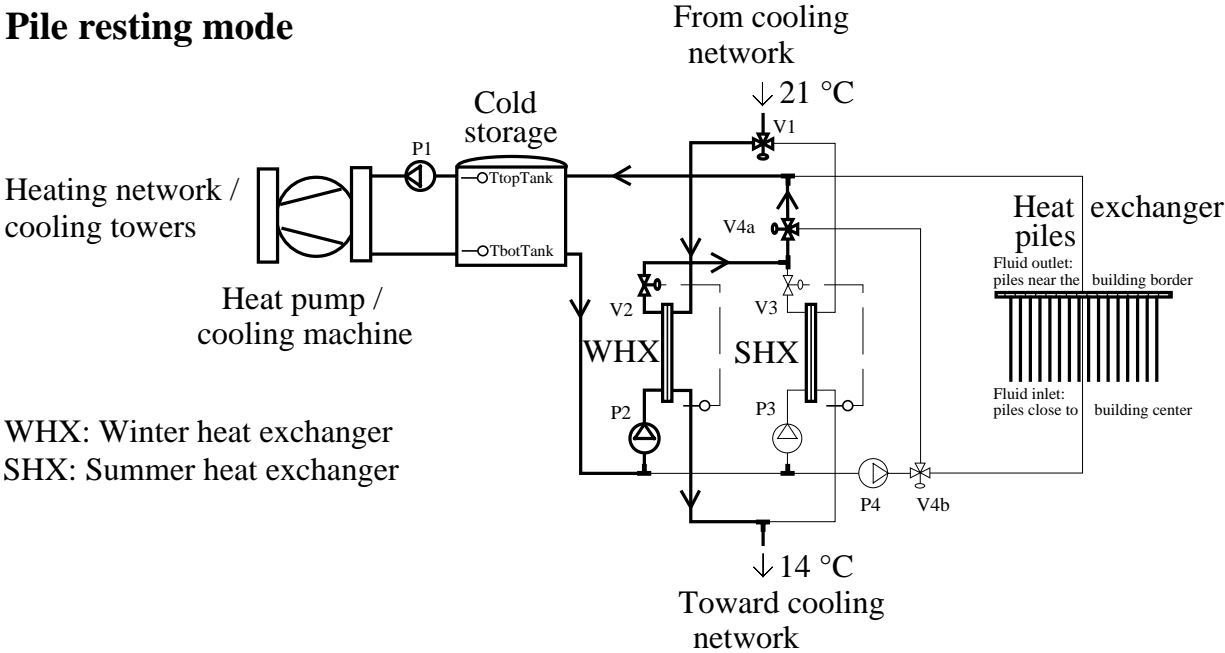

Fig. 5.5 Pile resting mode: the pile pump P4 is stopped and the three-way valve V4a prevent the fluid from flowing through the piles. The heat pump may operate if there is a heating demand.

During the “pile resting mode”, the cooling machine is not used. If the fluid temperature at the bottom of the cold storage rises, direct cooling with the piles is tried first (the operational mode switches back to the “pile cooling mode”). If there is a heating demand, the heat pump is switched on and the fluid temperature is likely to decrease. Below a given threshold, the “pile heating mode” is switched on. The “pile heating mode” is shown in figure 5.6.

## Pile heating mode

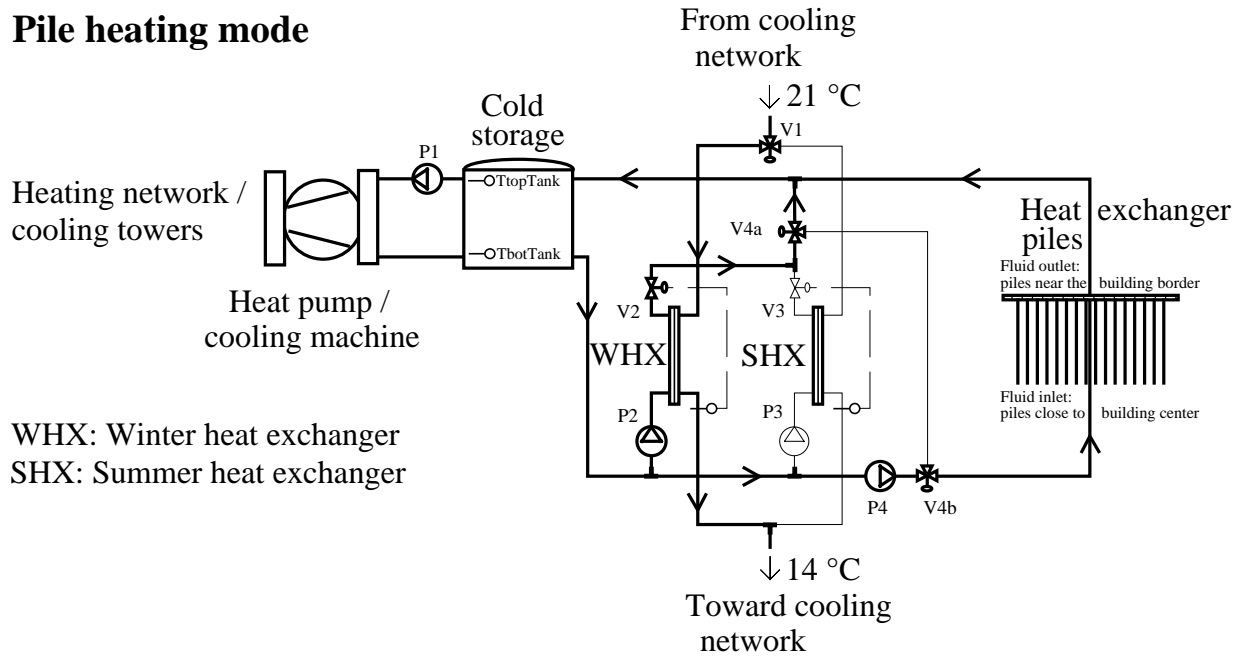

Fig. 5.6 Pile heating mode: the pile pump P4 is switched on and the three-way valve V4a and V4b prevent the fluid from flowing between them.

During the “pile heating mode”, the cooling distribution and the heat exchanger piles are coupled in parallel. They both supply heat to the heat pump evaporator. The power of the heat pump has to be decreased if the fluid temperature drops below 0 °C.

### 5.4 The System Control

The system control has the task to control and operate all the components of the system. In this section, the control strategy used in the simulation is described. The ON / OFF setting of the three-way valves refers to figure 5.1. For clarity purposes, the system control is divided into 4 groups:

- the summer and winter heat exchangers;
- the system operational modes;
- the heat pump;
- the cooling machine.

#### Summer and Winter Heat Exchangers

It concerns the control of V1, P2, V2, P3 and V3. A ON/OFF controller is used to set the three-way valve V1. This controller has dead band temperature differences which provide an hysteresis effect to avoid an unstable control situation.

- **ON/OFF controller for the three-way valve V1:**

TH = TbotTank                      (TH - TL) > 0.5 K    ⇒ three-way valve V1: ON (SHX used)

TL = Tmax(Pcold) - 0.5      (TH - TL) < 0 K    ⇒ three-way valve V1: OFF (WHX used)

The temperature  $T_{botTank}$  is the fluid temperature at the bottom of the cold storage. The temperature  $T_{max}$  depends on the cooling power demand  $P_{cold}$  and is known from the design characteristics of the winter heat exchanger (see figure 5.3). In figure 5.7, the hysteresis effect of the ON/OFF controller is illustrated.

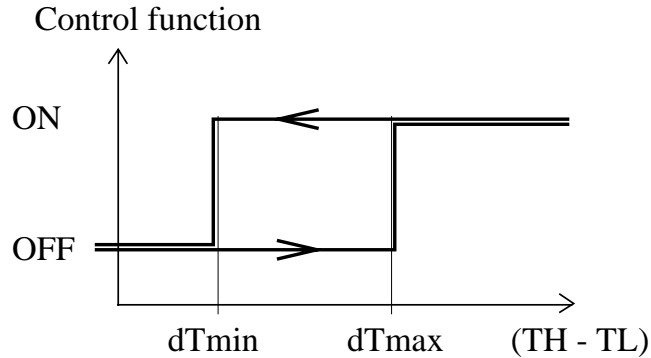

Fig. 5.7 Hysteresis effect provided by the ON/OFF controller. The dead band temperature differences are  $dT_{max}$  and  $dT_{min}$ , set to respectively 0.5 and 0 K for the ON/OFF controller assigned to the valve V1.

- **Pump P2** (flow in the primary side of the WHX)  
V1: OFF **and** Cooling demand : YES  $\geq$  pump P2 : ON  
V1: ON **or** Cooling demand : NO  $\geq$  pump P2 : OFF  
The nominal flow rate value (maximum flow rate) is 23 m<sup>3</sup>/h.
- **Two-way valve V2** (control the flow rate in the primary side of the WHX)  
The flow rate is adjusted by the two-way valve V2 so that the outlet fluid temperature on the secondary side of the heat exchanger is equal to 14 °C.
- **Pump P3** (flow in the primary side of the SHX)  
V1: ON **and** Cooling demand : YES  $\geq$  pump P3 : ON  
V1: OFF **or** Cooling demand : NO  $\geq$  pump P3 : OFF  
The nominal flow rate value (maximum flow rate) is 80 m<sup>3</sup>/h.
- **Two-way valve V3** (control the flow rate in the primary side of the SHX)  
The flow rate is adjusted by the two-way valve V3 so that the outlet fluid temperature on the secondary side of the heat exchanger is equal to 14 °C.

### System Operational Modes

The three operational modes are determined by the temperature  $T_{botTank}$ , the fluid temperature at the bottom of the cold storage. They control P4, V4a and V4b. The fluid temperature at the bottom of the cold storage may vary between 0 and 12 °C. The diagram of figure 5.8 shows the three temperature domains assigned to each system operational mode.

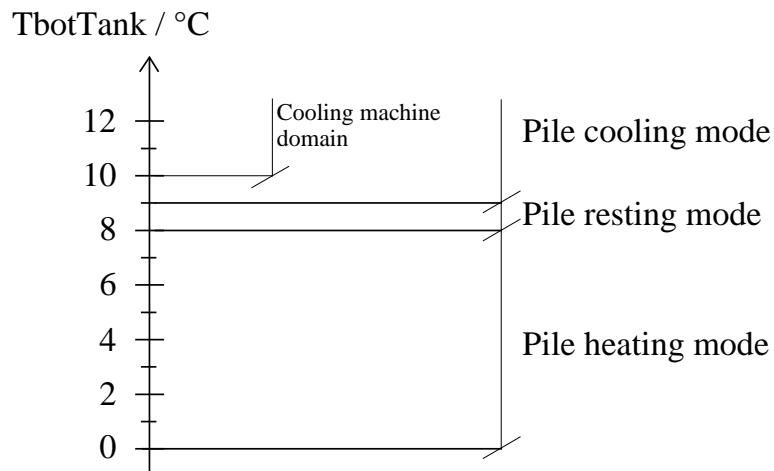

Fig. 5.8 The three operational modes of the system are defined by the fluid temperature at the bottom of the cold storage ( $T_{botTank}$ ). The diagram shows the setting used for the simulations. The cooling machine domain is entirely enclosed in the pile cooling mode.

Two ON/OFF controllers are used to select the suitable mode. The procedure for the determination of the operational mode is defined as follow:

- **ON/OFF controller for the “pile heating mode”:**

$$\begin{aligned} TH &= T_{botTank} & (TH - TL) > 1 \text{ K} & \Rightarrow \text{NoHeat} = \text{TRUE} \\ TL &= 8 - 0.5 = 7.5 \text{ }^\circ\text{C} & (TH - TL) < 0 \text{ K} & \Rightarrow \text{NoHeat} = \text{FALSE} \end{aligned}$$

If (NoHeat = FALSE) then “Pile heating mode” = TRUE  
 else “Pile heating mode” = FALSE

- **ON/OFF controller for the “pile resting mode”:**

$$\begin{aligned} TH &= T_{botTank} & (TH - TL) > 1 \text{ K} & \Rightarrow \text{NoRest} = \text{TRUE} \\ TL &= 9 - 0.5 = 8.5 \text{ }^\circ\text{C} & (TH - TL) < 0 \text{ K} & \Rightarrow \text{NoRest} = \text{FALSE} \end{aligned}$$

The “Pile resting mode” can be activated only if the “Pile heating mode” is not activated:

If (NoRest = FALSE) and (NoHeat = TRUE) then “Pile resting mode” = TRUE  
 else “Pile resting mode” = FALSE

The “Pile cooling mode” can be activated only if the “Pile heating mode” and the “Pile resting mode” are both not activated:

If (NoRest = TRUE) and (NoHeat = TRUE) then “Pile cooling mode” = TRUE  
 else “Pile cooling mode” = FALSE

- **Pump P4 (flow through the piles), three-way valves V4a and V4b**

|                               |      |   |             |     |
|-------------------------------|------|---|-------------|-----|
| If “Pile heating mode” = TRUE | then | ➤ | pump P4 :   | ON  |
|                               |      |   | valve V4a : | OFF |
|                               |      |   | valve V4b : | OFF |
| <br>                          |      |   |             |     |
| If “Pile resting mode” = TRUE | then | ➤ | pump P4 :   | OFF |
|                               |      |   | valve V4a : | OFF |
|                               |      |   | valve V4b : | OFF |
| <br>                          |      |   |             |     |
| If “Pile cooling mode” = TRUE | then | ➤ | pump P4 :   | OFF |
|                               |      |   | valve V4a : | ON  |
|                               |      |   | valve V4b : | ON  |

When the pump P4 is used, the flow rate through the pile is constant. The flow rate is set to 125 m<sup>3</sup>/h.

### Heat Pump

The heat pump can operate at 4 different regimes (25%, 50%, 75% and 100% of the nominal power). However, a simple model has been used in the simulations, which is actually the model used in PILESIM. The same parameters were used: a design electric power of 140 kW and a constant performance coefficient of 4.5. The power of the heat pump is continuously adjusted to match the heating demand of the building up to the design value. The heat pump power is reduced if the fluid temperature drops below 0 °C at the evaporator outlet.

The simulation of the heat pump operation requires a model which can take into account the losses due to the switch on and off of the heat pump as well as the regime changes. The time-step used in the simulations (45 sec) is small enough to reproduce a realistic operation of the heat pump. However, the purpose of the present simulations where to understand the system dynamic and not to simulate a precise operation of the heat pump, which requires the knowledge of the heat pump’s thermal behaviour. This latter is normally known for a particular machine from the data given by the manufacturer (thermal and electric power values given for the whole range of fluid temperatures in the evaporator and condenser).

Some recommendations and a proposition for the heat pump control is nevertheless given in this section, based on past experience gained with the comparison of measurements and simulations related to three heat pumps operating in parallel (Fromentin et al., 1997). The heat pump model used was the TYPE 201 (Afjei et al., 1996), taken from the YUM programme (Afjei, 1989). An important result is that the heat pump control has a considerable influence on the average performance coefficient of the heat pump. A difference of up to 0.4 on the seasonal performance coefficient was simulated between a “bad” and a “good” heat pump control. A “good” heat pump control minimises the number of regime changes so that the time between two regime changes (control decisions) is maximised. A delay of 5 to 10 minutes between two control decisions has to be taken into account by the regulation. Furthermore, if a temperature criterion requires to increase the heat pump regime, the decision is ignored if the temperature difference between the desired and the measured temperature is decreasing. The fluid temperature used to control the heat pump is normally measured in a buffer storage between the heat distribution and the heat pump condenser. In the case of Dock Midfield, there will not be a buffer storage. The amount of fluid in the heat distribution is large enough

to replace one. The fluid temperature to control the heat pump operation can be the return fluid temperature from the heat distribution. The desired return fluid temperature TS depends on the outside temperature. The measured return fluid temperature is labelled TM. A control procedure for the heat pump operation is proposed below:

- **Heat pump operation:**

If (*HeatingDemand* = FALSE) or “Cooling Machine ON” then

    “Heat Pump OFF” or PACregime = 0%

    “District Heating OFF”

Else if ( $\Delta t > \text{DELAY}$ ) and ( $T_{\text{botTank}} < 0^\circ\text{C}$ ) then

    PACregime = PACregime - 25%

    If PACregime < 0% then PACregime = 0%

*HeatPumpMax* = TRUE

Else

*HeatPumpMax* = FALSE

    if ( $\Delta t > \text{DELAY}$ ) and ( $TM < (TS - \text{TOL})$ ) and ( $TS - TM > TS_{-1} - TM_{-1}$ ) then

        PACregime = PACregime + 25%

        If PACregime = 125% then *DistrictHeat* = TRUE

        If PACregime > 100% then PACregime = 100%

    if ( $\Delta t > \text{DELAY}$ ) and ( $TM > (TS + \text{TOL})$ ) and ( $TM - TS > TM_{-1} - TS_{-1}$ ) then

*DistrictHeat* = FALSE

        PACregime = PACregime - 25%

        If PACregime < 0% then PACregime = 0%

End

- **District heating:**

If (“*HeatingDemand*” = TRUE) and

    ((*HeatPumpMax* = TRUE) or (*DistrictHeat* = TRUE)) then

    “Add district energy to meet the temperature criterion TS”

    If “district energy is null” then *DistrictHeat* = FALSE

End

The “PACregime” is the regime of the heat pump and may only vary between 0 and 100% by steps of 25%. The variables are:

$\Delta t$  : time elapsed from the last control decision;

DELAY : delay imposed between each control decision;

$T_{\text{botTank}}$  : fluid temperature at the bottom of the cold storage (see figure 5.1);

TM : measured return fluid temperature at the time of the procedure assessment t;

$TM_{-1}$  : old measured return fluid temperature at the time (t-DELAY);

TS : set return fluid temperature at the time of the procedure assessment t;

$TS_{-1}$  : old set return fluid temperature at the time (t-DELAY);

TOL : temperature tolerance;

*HeatingDemand* = TRUE: there is a heat demand;

= FALSE: there is no heat demand;

*HeatPumpMax* = TRUE: heat pump power reduced to meet the minimum fluid temperature in the piles. District energy needed;

= FALSE: heat pump power not constrained;

*DistrictHeat* = TRUE: district energy is required;

= FALSE: no district energy is necessary.

### Cooling Machine

The same machine is used for heating and cooling. The machine has two condensers; one is connected to the heat distribution and the other to cooling towers. Depending on which condenser is used, the machine works as a heat pump or a cooling machine. In the simulations, only the cooling energy provided by the cooling machine is calculated. When the fluid temperature at the bottom of the cold storage (TbotTank) exceeds 12 °C, the forward fluid temperature to SHX or WHX is arbitrary set to 11 °C. The cooling energy provided by the cooling machine is known from the temperature difference with TbotTank and the flow rate through SHX or WHX. If TbotTank is lower than 12 °C, the forward fluid temperature is not modified and the cooling energy is null. This simple way of calculating the cooling energy provided by the cooling machine do not stop the heat pump operation. However this simplification has a negligible influence. A simulation has shown that the annual heating energy delivered during the cooling machine operation amounts to only 0.5% of the total annual energy delivered by the heat pump.

The temperature at the bottom of the cold storage do not need to be always below 12 °C. This is only necessary if the cooling power is 700 kW. If TbotTank rises up to 13.5 °C, a cooling power of 500 kW can still be transferred by SHX. As a consequence, the maximum allowed temperature at the bottom of the cold storage TMAX may also be a function of the cooling power demand. A proposition for the cooling machine control is given below:

- **Cooling machine operation:**

If (*CoolingDemand* = FALSE) then

    “Cooling Machine OFF” or COMregime = 0%

Else if ( $\Delta t > \text{DELAY}$ ) and ( $TM > (TMAX - TOL1)$ ) and ( $TM - TMAX > TM_{.1} - TMAX_{.1}$ )  
then

    COMregime = COMregime + 25%

    If COMregime > 100% then COMregime = 100%

    “Cooling Machine ON”

if ( $\Delta t > \text{DELAY}$ ) and ( $TM < (TMAX - TOL2)$ ) and ( $TMAX - TM > TMAX_{.1} - TM_{.1}$ )  
then

    COMregime = COMregime - 25%

    If COMregime < 0% then COMregime = 0%

    “Cooling Machine OFF”

End

The COMregime is the regime of the cooling machine and may only vary between 0 and 100% by steps of 25%. The variables are:

$\Delta t$  : time measured from the last control decision;

DELAY : delay imposed between each control decision;

TbotTank : fluid temperature measured at the bottom of the cold storage (see figure 5.1);

TM : TbotTank at the time of the procedure assessment t;

TM<sub>.1</sub> : old measurement TbotTank at the time (t-DELAY);

TMAX : maximum allowed fluid temperature at the time of the procedure assessment t;

TMAX<sub>.1</sub> : old maximum allowed fluid temperature at the time (t-DELAY);

TOL1 : temperature tolerance associated to the switch on of the cooling machine;

TOL2 : temperature tolerance associated to the switch off of the cooling machine



(TOL2>TOL1);

*CoolingDemand* = TRUE: there is a cooling demand;  
 = FALSE: there is no cooling demand;

- **Pump P1** (flow through the machine evaporator)

If “Cooling Machine ON” then ≥ pump P1 : ON  
 Else If “Heat Pump ON” then ≥ pump P1 : ON  
 Else ≥ pump P1 : OFF

### 5.5 Main Input Parameters of the Reference System

All the parameters used in PILESIM are also used in the detailed simulations. The additional information for the system layout, the system control and the heat exchangers (SHX and WHX) is described in the previous sections. In this section, the parameters concern the cold storage and the horizontal pipes that lie in the technical galleries of the building (see tables 5.3 and 5.4).

|                              |                   |
|------------------------------|-------------------|
| Volume of fluid              | 15 m <sup>3</sup> |
| Storage insulation thickness | 10 cm             |

Table 5.3 Cold storage characteristics.

|  |  |
|--|--|
| Inside pipe diameter                   | 0.1 m  |
| Pipe insulation thickness              | 3 cm   |
| Length of the forward pipes            | 1'250 m                                      |
| Length of the return pipes             | 1'250 m                                      |
| Ambient temperature for thermal losses | 20 °C (room air temperature of the building) |

Table 5.4 Characteristics of the horizontal pipes in the building technical galleries.

### 5.6 Output Results Obtained with the Detailed Model of the System

In the first part of this chapter, the results are presented as for the PILESIM simulation, in order to facilitate a comparison. Then the dynamic behaviour of the system is illustrated and finally the influence of several parameters on the thermal performances of the system are presented.

#### Results from the Detailed Model of the System

The temperature evolution of the inlet and outlet fluid temperature in the piles, simulated with the detailed model, is shown for the 10<sup>th</sup> operation year in figure 5.9. During heat extraction (i.e. the “pile heating mode”) the flow rate is constant and set to 125 m<sup>3</sup>/h. During heat injection (i.e. the “pile cooling mode”), the flow rate is variable and is equal to the flow rate through the SHX or the WHX.

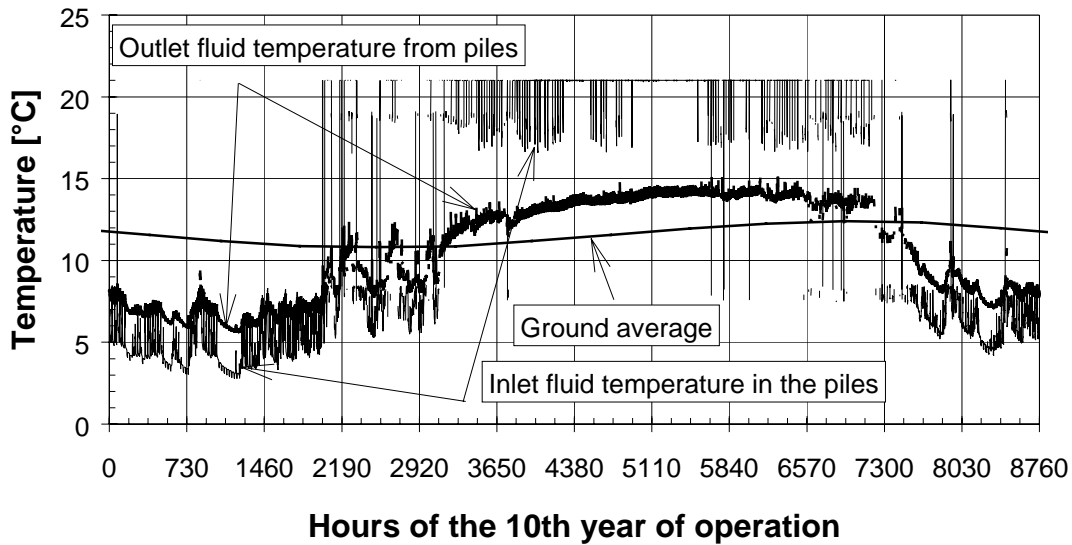

Fig. 5.9 Temperature evolution of the inlet and outlet fluid temperature in the piles for the 10<sup>th</sup> year of operation, simulated with the detailed model of the system. The average ground temperature in the pile region is also shown.

In figure 5.10 and 5.11, the diagrams shows the annual energy fluxes through the pile system and the heat exchanger piles.

### GLOBAL SYSTEM HEAT BALANCE

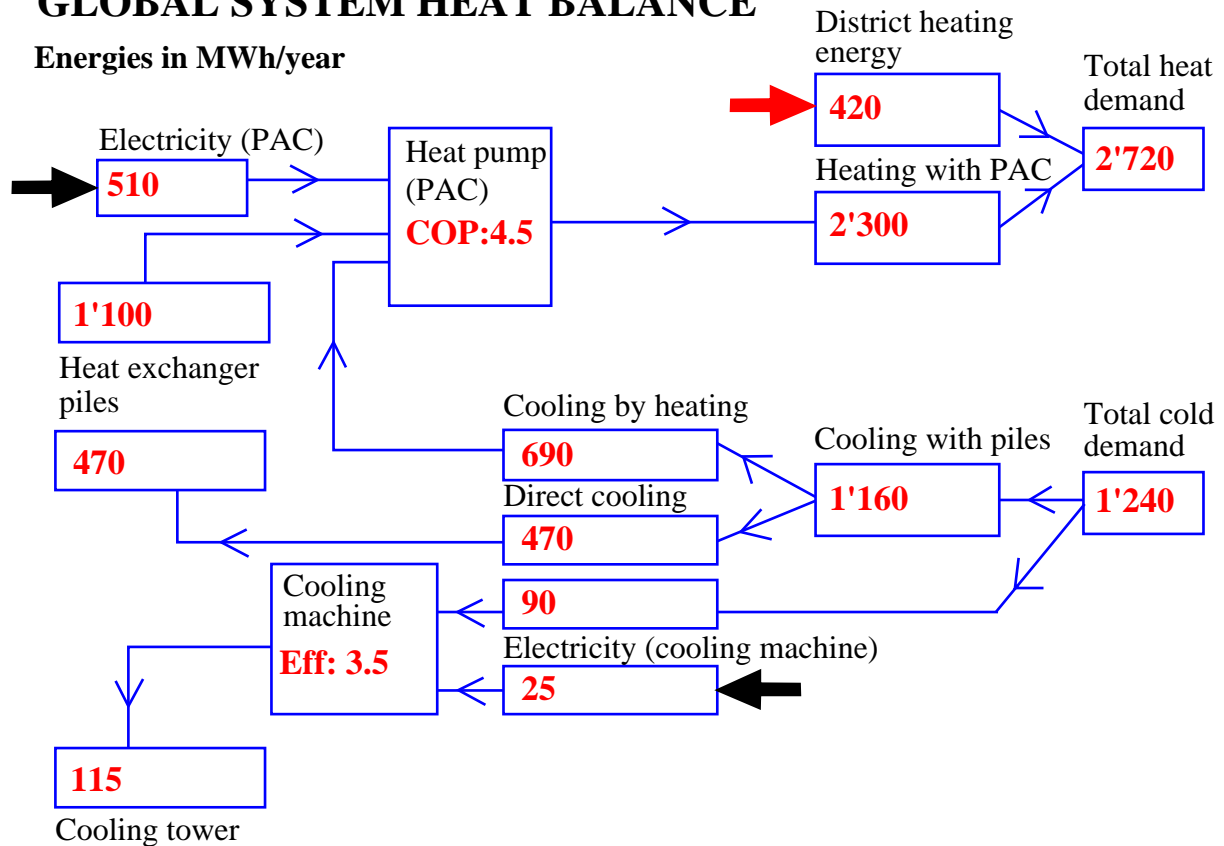

Fig. 5.10 Annual energy fluxes through the pile system, average values for the first 10 years of operation (simulated with the detailed model of the system).

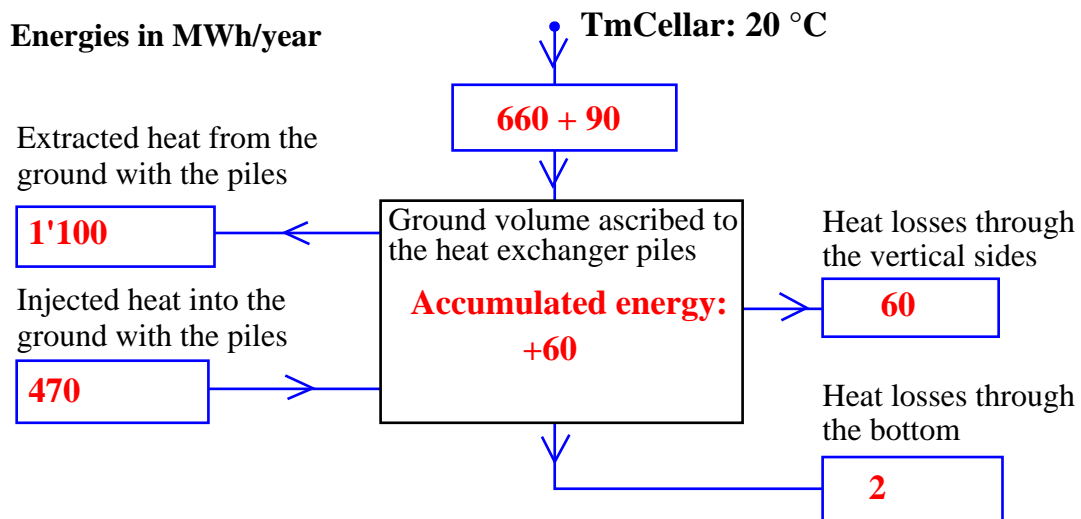

Fig. 5.11 Annual energy fluxes through the heat exchanger piles, average values for the first 10 years of operation (simulated with the detailed model of the system).

As expected, the main difference with the PILESIM simulation is the direct cooling energy, which is calculated to 470 MWh/year instead of 400 MWh/year (+18%). It highlights the importance of the temperature level used for direct cooling, which is better taken into account when a variable flow rate is implemented. (In PILESIM, the flow rate is constant when direct cooling is performed). Compared to the PILESIM simulation, the overall cooling energy provided by the piles is increased by 7%. The annual fraction of cooling energy covered by the piles rises from 87% to 93%. The annual fraction of heating energy covered by the heat pump is 85%. The heat losses from the building to the ground are lower (660 MWh/year), but the reduction is compensated by the building losses into the horizontal pipes in the technical galleries (90 MWh/year).

The heat rate and annual energies extracted and injected through the piles are, per unit length of heat exchanger piles (total active length of heat exchanger piles: 8'200 m):

**Detailed simulation:**

|                 |           |            |            |                   |
|-----------------|-----------|------------|------------|-------------------|
| <b>Heating:</b> | <b>49</b> | <b>W/m</b> | <b>135</b> | <b>kWh/m year</b> |
| <b>Cooling:</b> | <b>40</b> | <b>W/m</b> | <b>58</b>  | <b>kWh/m year</b> |

The maximum cooling power on the piles is simulated to 40 W/m. With PILESIM, it was found to be 49 W/m, due to the fact that the instantaneous fraction of the satisfied cooling demand was more irregular. During the 10<sup>th</sup> year of operation, the maximum auxiliary cooling power was found to be 330 kW, whereas it is only 140 kW with the detailed simulation model (with a variable flow rate). This highlights the importance of a variable flow rate through the piles in the cooling mode. The size of the auxiliary cooling units can be smaller.

### Dynamic Behaviour of the System

In the graph of figure 5.12, the fluid temperature at the bottom of the cold storage is shown for the 10<sup>th</sup> year of operation, together with the operational system mode.

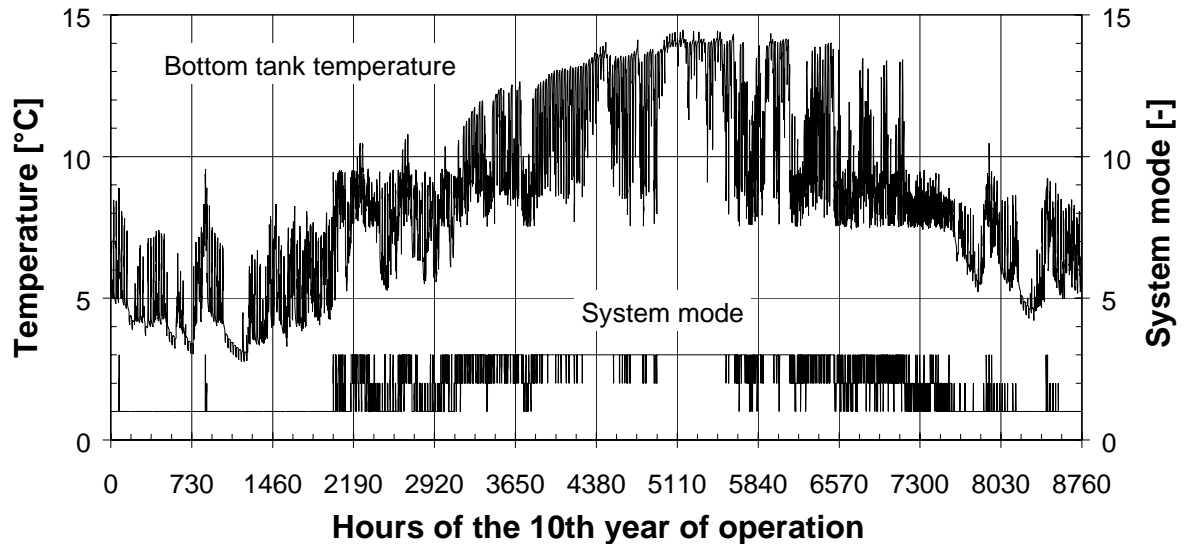

Fig. 5.12 Temperature evolution of the fluid at the bottom of the cold storage for the 10<sup>th</sup> year of operation, simulated with the detailed model of the system. The operational mode is shown with the following convention: 1: "pile heating mode"; 2: "pile resting mode"; 3: "pile cooling mode".

The forward fluid temperature to the primary side of the cooling heat exchangers never exceeds 12 °C in the reference system. This temperature is also equal to the fluid temperature at the bottom of the cold storage. However it can be seen in figure 5.12 that this latter rises sometimes over 12 °C. This is due to the way how the cooling machine is treated in the simulation model of the system: when the fluid temperature at the bottom of the cold storage exceeds 12 °C, the forward fluid temperature to the cooling heat exchangers is arbitrary set to 11 °C. The cooling energy provided by the cooling machine is thus known from the temperature difference between the bottom fluid temperature in the cold storage and the forward fluid temperature to the cold heat exchangers, set to 11 °C when the cooling machine is used.

As expected, the "pile heating mode" is predominant in winter and the "pile cooling mode" during the summer. In spring and autumn, all the mode are observed and may alternate several times during a day. In figure 5.13, the system dynamic is shown during a day in April.

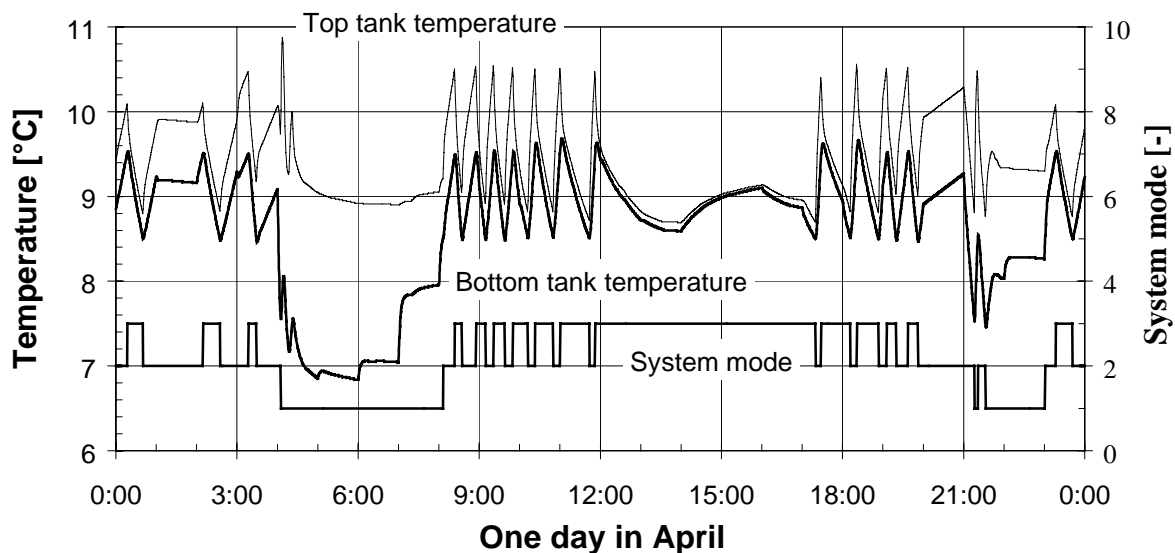
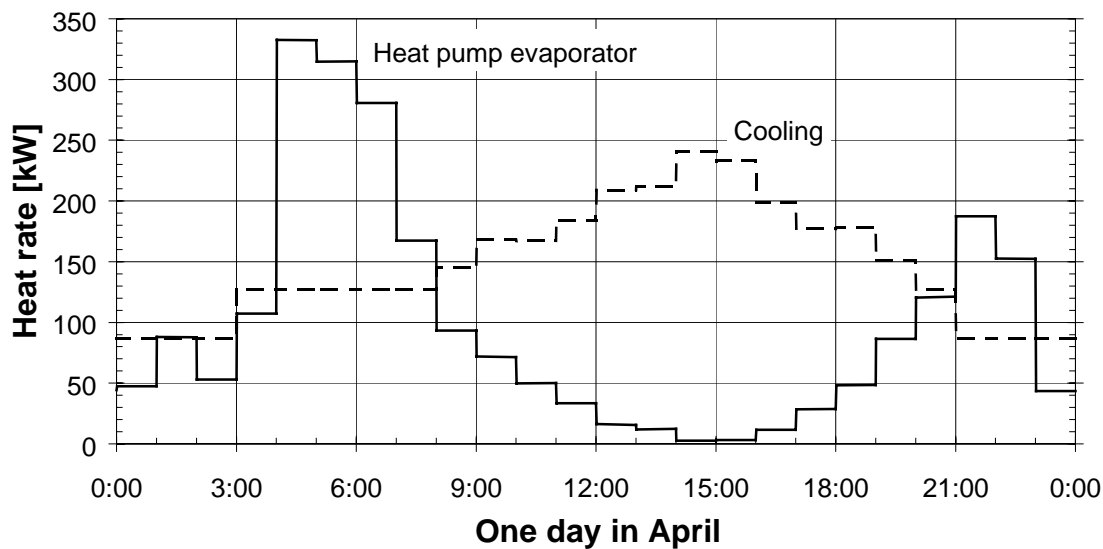

Fig. 5.13 The system dynamic is simulated with a time-step of 45 sec. The two graphs illustrate the response of the system to the heating and cooling demand. The fluid temperatures are simulated in the cold storage.

The cold storage temperatures tend to be stratified by the heat pump, whereas the cooling demand has the opposite effect. The cooling energy is either delivered through the SHX or the WHX. The results from the simulation are summarised in table 5.5.

|                          | SHX (Summer Heat Exch.)   | WHX (Winter Heat Exch.)     |
|--------------------------|---------------------------|-----------------------------|
| Nominal flow rate        | 80 m <sup>3</sup> /h      | 23 m <sup>3</sup> /h        |
| Minimum during operation | 8 m <sup>3</sup> /h (10%) | 4.2 m <sup>3</sup> /h (18%) |
| Cooling energy delivered | 640 MWh/year (52 %)       | 600 MWh/year (48 %)         |

Table 5.5 Minimum flow rate through the heat exchangers during operation (in the primary side) and annual cooling energy delivered.

The criterion used to select the SHX or the WHX has a great importance on the minimum flow rate during operation. If only the fluid temperature is used for the selection (the SHX is used if the inlet fluid temperature is greater than 4 °C), the minimum flow rate in the SHX is halved.

A trial with a larger WHX, 200 kW sized for an inlet fluid temperature of 6 instead of 4 °C, did not rise the minimum flow rate during operation. However a lower heat exchanger, 200 kW sized for an inlet fluid temperature of 0 instead of 4 °C, result in a smaller minimum flow rate in the SHX (8% instead of 10% of the nominal flow rate). Nevertheless, the minimum flow rate values are simulated for “clean” heat exchangers. The UA value of a heat exchanger normally decreases a little after some time. It will result in greater flow rates through the heat exchanger.

### Sensitivity to Some Parameters

The influence of some parameters on the system thermal performances is assessed and shown in this section. Only one or two parameters are varied at a time, all the other ones have the value of the reference system. The thermal performances of the reference system were presented in the previous section. The description of the varied parameters is presented below:

#### Case 1 Heating

##### **COP = 4 instead of 4.5**

The electric power consumed by the heat pump is the same. As a result, the heat rate extracted at the evaporator is reduced from 490 to 420 kW and the heat rate delivered at the condenser from 630 to 560 kW.

##### **COP = 5 instead of 4.5**

The effect is the opposite: the heat rate extracted at the evaporator is increased from 490 to 560 kW and the heat rate delivered at the condenser from 630 to 700 kW.

#### Case 2 Cooling

##### **-20 % cooling**

The cooling demand is decreased by 20 %.

##### **+20 % cooling**

The cooling demand is increased by 20 %.

#### Case 3 Cooling machine

##### **10 °C instead of 11°C**

When the cooling machine is operating, the fluid flowing to SHX is set to 10 instead of 11 °C.

##### **12 °C instead of 11°C**

When the cooling machine is operating, the fluid temperature flowing to SHX is set to 12 instead of 11 °C.

##### **Max temperature 13.5 instead of 12 °C**

The maximum allowed temperature in the bottom of the cold storage is increased from 12 to 13.5°C. When the cooling machine is operating, the fluid temperature flowing to SHX is set to 12.5 instead of 11 °C.

Case 4 Temperature level **T return set to 19 °C instead of 21 °C**

The return fluid temperature from the cooling distribution is decreased from 21 to 19 °C.

Case 5 System control **“Pile heating mode” changed to “pile resting mode” at 6 instead of 8 °C**

The criterion to change between the “pile heating mode” and the “pile resting mode” is set at 6 instead of 8 °C.

**Ditto and “pile resting mode” changed to “pile cooling mode” at 7 instead of 9 °C**

The criterion to change between the “pile heating mode” and the “pile resting mode” is set at 6 instead of 8 °C, and the criterion to change between the “pile resting mode” and the “pile cooling mode” is set at 7 instead of 9 °C.

The influence of these parameter variations is assessed on the following heat quantities:

- **QevPAC**: annual energy extracted at the heat pump evaporator;
- **QextGrnd**: annual energy extracted from the heat exchanger piles;
- **QDirCool**: annual cooling energy injected into the heat exchanger piles (direct cooling energy);
- **QCoolTot**: annual cooling energy satisfied by the heat pump and the piles.

The results are summarised in table 5.6.

| Energies in MWh/year              | QevPAC       | QextGrnd     | QDirCool   | QCoolTot     |
|-----------------------------------|--------------|--------------|------------|--------------|
| Reference system                  | 1'790 (ref.) | 1'100 (ref.) | 470 (ref.) | 1'160 (ref.) |
| Case 1: COP = 4 instead of 4.5    | 1'640 -8%    | 960 -13%     | 450 -4%    | 1'130 -2%    |
| COP = 5 instead of 4.5            | 1'920 +7%    | 1'230 +11%   | 490 +4%    | 1'180 +2%    |
| Case 2: -20 % cooling             | 1'790 -      | 1'220 +10%   | 400 -16%   | 970 -17%     |
| +20 % cooling                     | 1'790 -      | 1'000 -10%   | 530 +13%   | 1'330 +15%   |
| Case 3: Cooling machine / 10 °C   | 1'790 -      | 1'100 -      | 450 -4%    | 1'140 -2%    |
| Cooling machine / 12 °C           | 1'790 -      | 1'100 -      | 490 +4%    | 1'180 +2%    |
| Max. temp.: 13.5 °C               | 1'790 -      | 1'100 -      | 510 +8%    | 1'200 +3%    |
| Case 4: Return temp. level: 19 °C | 1'790 -      | 1'100 -      | 450 -4%    | 1'140 -2%    |
| Case 5: System control: 6°C       | 1'790 -      | 1'100 -      | 470 -      | 1'160 -      |
| Syst. ctrl: 6°C and 7°C           | 1'790 -      | 1'100 -      | 470 -      | 1'160 -      |

Table 5.6 Influence of some parameters on the thermal performances of the system.

As expected, the thermal performances of the heat pump has an influence on the direct cooling energy absorbed by the piles. With a performance coefficient of 5, the temperature criterion on the fluid in the piles ( $> 0$  °C) is still met without a reduction of the heat pump regime. The design heat rate extracted at the evaporator is increased to 560 kW. As the cooling power during the year is always greater than 90 kW, at the most 470 kW are extracted

from the piles (or 57 W/m). This value is 16% greater than the reference system. This gives an indication on the security factor given on the reference system.

The results given in table 5.6 highlight the following points for satisfactory thermal performances of the system:

- it is important to let the fluid temperature at the bottom of the cold storage rise as much as possible in relation to the thermal characteristics of the summer heat exchanger (SHX) and the cooling power to be transferred;
- when the cooling machine is working, the fluid temperature at the bottom of the cold storage should be kept as high as possible. A low temperature should stop the cooling machine operation;
- the return fluid temperature from the cooling distribution should be as high as possible. A low return fluid temperature penalises the direct cooling energy and the system thermal performances.

The temperature criteria to choose between the three operational system modes do not need to be calibrated or optimised for best system thermal performances. The change of the temperature level for the selection of the system mode has a weak influence (less than 1% on the thermal performances in the varied temperature range).



## Conclusion

Thank to the planned Dock Midfield at Zürich airport, this project was made possible, due to the need of simulation procedures for the design of the heat exchanger pile system. The transient system simulation programme TRNSYS was used together with a non standard simulation model adapted for the simulation of heat exchanger piles (TRNVDSTP). TRNSYS simulation tools developed and validated in a previous project have been used and adapted to the Dock Midfield case. They were used every time the heating and cooling demand was known more precisely and helped to solve design problems (pure water or antifreeze, size of the heat pump, number of piles used, etc.). A response test has been performed to determine in situ the mean effective thermal conductivity of the ground. As the input information to the programme became more accurate, the degree of details in the simulation tools rose. The final simulation took into account the system layout, including the pumps, valves and heat exchangers, and the system control. The thermal behaviour of the pile system has been simulated as close as possible as the real system would be. It helped optimise the system layout and to define the system control. Hopefully, the time required for the startup of the real system will be shortened and the real system thermal performances will be close to the expectations.

This project also provided a good opportunity to develop a simulation tool for the design of heat exchanger pile systems. There is a need for a such tool which can be used by people who are not necessarily experts in system simulation and TRNSYS, and which still provides sufficient flexibility for a large variety of system concepts. The experience gained in the simulation of such systems was used to create PILESIM. PILESIM assumes an ideal system layout and control. The required time to use the programme and perform a simulation is reasonably short. The thermal performances calculated with PILESIM are close to those obtained with the detailed simulation model.

Finally, the Dock Midfield case provides an interesting illustration on how a project evolves and how the concept of a heat exchanger pile system develops in a practical realisation.

## References

- AFJEI Th. (1989) YUM; A Yearly Utilisation Model for Calculating the Seasonal Performance Factor of Electric Driven Heat Pump Heating Systems, Technical Form; Eidgenössische Technische Hochschule Zürich, IET - LES; Zürich, Switzerland.
- AFJEI Th. et al. (1996) Kostengünstige Niedrigtemperaturheizung mit Wärmepumpe; Phase 1: Machbarkeitsanalyse, Problemanalyse und Vorbereitung zum Bau eines Funktionsmusters, Schlussbericht, Bundesamtes für Energiewirtschaft, ENET-Nummer 9655701, Schweiz.
- DIAS (1996) CUEPE IAUG, Université de Genève, Suisse.
- JÄCKLI H. (1996) Airport 2000, 5. Bauetappe Zurich Flughafen, Dock Midfield, Hydrogeologische Grundlagen für geothermische Nutzung, Dr. Heinrich Jäckli AG, Zürich.
- FROMENTIN A., PAHUD D., JAQUIER C. & MORATH M. (1997) Recommandations pour la réalisation d'installations avec pieux échangeurs. Empfehlungen für Energiepfahlsysteme, Rapport final, Office fédéral de l'énergie, Bern, Switzerland.
- HUBBUCH M. (1999) Funktionsbeschreibung der Umluftkälteerzeugung / Energiepfahlkreis / Wärmeverteilnetz. ARGE ZAYETTA, 8058 Zürich-Flughafen.
- KLEIN S. A. et al. (1998) TRNSYS. A Transient System Simulation Program. Version 14.2. Solar Energy Laboratory, University of Wisconsin, Madison, USA.
- KOSCHENZ M. and WEBER R. (1997) Thermische Simulationsberechnungen Teil1. EMPA, Abt. Haustechnik, Dübendorf, Switzerland.
- KOSCHENZ M. and WEBER R. (1998) Thermische Simulationsberechnungen Teil2. EMPA, Abt. Haustechnik, Dübendorf, Switzerland.
- PAHUD D., HELLSTRÖM G. & MAZZARELLA L. (1996a) Heat Storage in the Ground. Duct Ground Heat Storage Model for TRNSYS (TRNVDST). User Manual for the October 1996 Version. LASEN - DGC- EPFL, Switzerland.
- PAHUD D., FROMENTIN A. & HADORN J.-C. (1996b) The Duct Ground Heat Storage Model (DST) for TRNSYS Used for the Simulation of Heat Exchanger Piles. User Manual, December 1996 Version. Internal Report. LASEN - DGC- EPFL, Switzerland.
- PAHUD D., FROMENTIN A. et HUBBUCH M. (1998) Response - Test für die Energiepfahlanlage Dock Midfield, Zürich Flughafen. Messung der Bodenleitfähigkeit in situ. Bundesamt für Energie, Bern, Switzerland.
- PAHUD D. (1999) PILESIM- LASEN: Simulation Tool for Heating / Cooling Systems with Heat Exchanger Piles or Borehole Heat Exchangers. User Manual. Laboratory of Energy Systems, Swiss Federal Institute of Technology in Lausanne, Switzerland.
- Recommandation SIA V382/2 (1992) Puissance de réfrigération à installer dans le bâtiment. Société suisse des ingénieurs et des architectes. Suisse.

# Appendix 1: The PILESIM Simulation Tool

## Content:

|  |         |
|--|---------|
| <b>A1.1 Introduction</b> .....                               | p. A1.1 |
| <b>A1.2 The PILESIM simulation tool</b> .....                | p. A1.1 |
| A1.2.1 What does PILESIM simulate ? .....                    | p. A1.2 |
| A1.2.2 How may PILESIM be used ? .....                       | p. A1.3 |
| A1.2.3 What does PILESIM calculate ? .....                   | p. A1.3 |
| A1.2.4 How does PILESIM calculate ? .....                    | p. A1.4 |
| A1.2.5 Main assumptions of the PILESIM simulation tool ..... | p. A1.5 |
| <b>A1.3 Conclusion</b> .....                                 | p. A1.6 |
| <b>References</b> .....                                      | p. A1.6 |

## **A1.1 Introduction**

A pile foundation is used when the upper layers of soil are too soft and compressible to support the loads of a superstructure, normally a building. A heat exchanger pile is a pile foundation equipped with a pipe system, in which a heat carrier fluid can be circulated so as to exchange heat with the surrounding ground. The two main functions of a heat exchanger pile are thus to support the loads of a superstructure and to serve as a heat exchanger with the ground. A heat exchanger pile system is comprised of a set of heat exchanger piles which are connected together hydraulically, and normally are coupled to a heat pump. Such a system is usually used for heating and/or cooling purposes.

The principal constraint on the system is that the thermal solicitations withstood by the piles must not deteriorate their mechanical properties, i.e., their ability to support the loads of the building. In particular, freezing of the piles must be avoided. In a safely sized heat exchanger pile system, the fluid temperature in the piles never drops below 0 °C for a long period of time. This temperature constraint influences the size of the heat pump, which in turn affects the heating potential provided by the heat exchanger piles. When direct cooling is performed, i.e. when the pile flow circuit is connected to the cold distribution without a cooling machine in between, the cooling potential also depends directly on the temperature level of the fluid in the cooling system. The annual extracted and injected thermal energy through the piles determines the evolution of the ground temperature year after year, which in turn may affect the thermal performances of the system. An accurate assessment of the heating and cooling potential offered by a heat exchanger pile system requests a dynamic simulation of the system, which takes into account both short-term and long-term thermal performances. It requires good knowledge of the system's thermal characteristics, the local ground conditions and the use of an accurate system simulation tool.

Simulation tools of heat exchanger pile systems have been developed in the Laboratory of Energy Systems (LASSEN), at the Swiss Federal Institute of Technology in Lausanne (EPFL) (see FROMENTIN et al. 1997). The experience gained in the simulation of such systems is used to create PILESIM (PAHUD 1999). The development of the simulation tools that were validated with measurements from existing systems (FROMENTIN et al. 1997) forms the basis of the programme. It offers easy use and relatively fast calculations. PILESIM may also be used for the simulation of ground coupled systems with a relatively large number of borehole heat exchangers. A borehole heat exchanger is a borehole equipped with a pipe system (for example with U-shape pipes) to exchange heat between the heat carrier fluid and the ground.

## **A1.2 The PILESIM simulation tool**

PILESIM has been developed with TRNSYS (KLEIN et al. 1998) and then adapted to the TRNSED format. Thanks to the TRNSED application, a stand alone programme can be created. In addition, the TRNSYS simulation tool is embedded in a user-friendly interface which provides online help and allows a non-specialist TRNSYS user to use the programme.

### A1.2.1 What does PILESIM simulate ?

In Fig. A1.1, a schematic view of the type of systems simulated by PILESIM is shown. A great flexibility has been given to PILESIM in order to provide a large variety of systems that can be simulated.

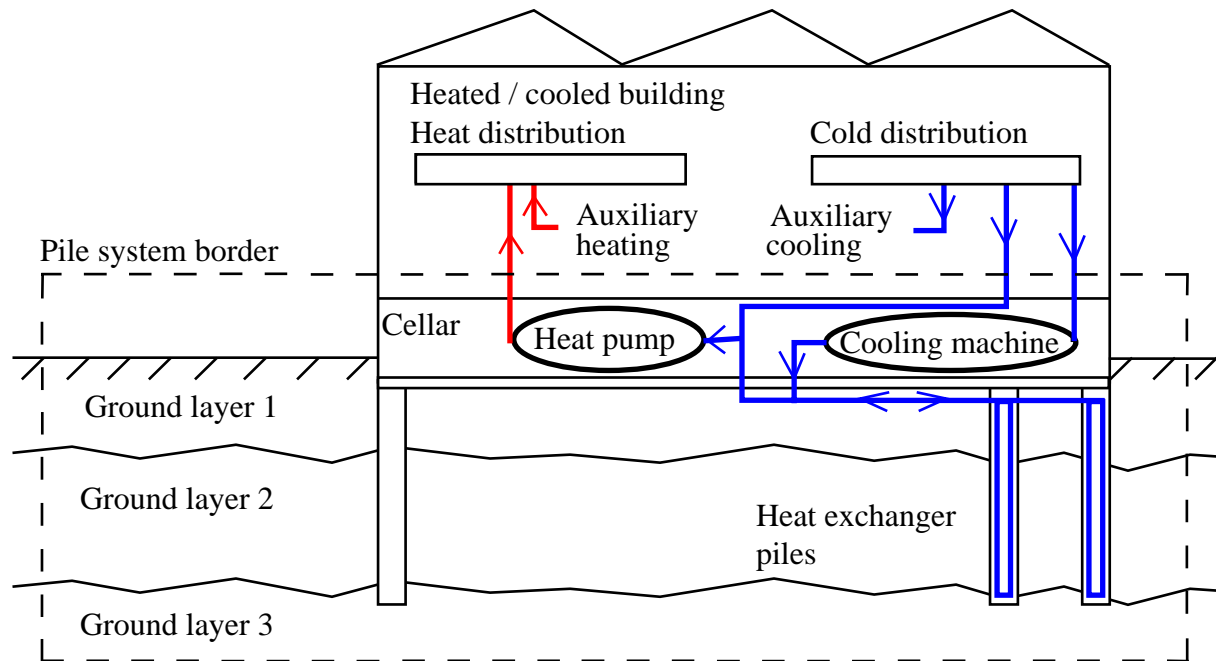

Figure A1.1 Schematic view of a heat exchanger pile system. The part of the system which is simulated by the PILESIM programme is delimited by the pile system border shown with the dashed line.

The pile system border shown in Fig. A1.1 indicates the limits of the thermal simulations. The heat transfers are calculated from the ground to the thermal energy distributed in the building (heating and cooling). In particular, the heat transferred by the piles, by the horizontal connecting pipes under the concrete plate of the cellar, through the floor and ceiling of the cellar are assessed. The cellar, assumed to be unheated, has a temperature which depends on the indoor building temperature, the outside air temperature and the ground temperature below the building. The cellar can be given the temperature of the outside air by an appropriate setting of heat transfer coefficients.

The loading conditions, determined by the heat demand, the cold demand and their corresponding temperature levels, are contained in a text file and read by the programme. Predefined values are stored in files for several locations and can readily be used for a simulation. These predefined loading conditions are established on the basis of simple models which determine the space heating and space cooling requirements. The user also has the possibility to use his own loading conditions with PILESIM, in order to make them correspond to his particular problem. A temporal evolution of the hourly loading conditions is required for a whole year.

Four different types of system can be simulated. Heating can either be combined with a thermal recharge of the ground during the summer, or with cooling which can be performed in three different manners: a cooling machine, direct cooling, or a combination of the two.

*A1.2.2 How may PILESIM be used ?*

PILESIM can be used in different ways, depending on the degree of knowledge of a project. At an early stage, a pre-simulation can be performed by using a predefined file for the loading conditions, a constant performance coefficient for the heat pump and a constant efficiency for the cooling machine. Later in the project, more will obviously be known about the building. The pile system's parameters will also be better known and more accurate loading conditions can be established with the help of another programme. They can be used to create an input data file for PILESIM, and a more precise simulation of the pile system can be performed, which may include the temperature-dependent heat pump performance coefficient and cooling machine efficiency.

*A1.2.3 What does PILESIM calculate ?*

The energies transferred between the different components of the systems are calculated and integrated on a monthly or a yearly basis. A global heat balance of the system can be made month by month or year by year. The Sankey diagram shown in Fig. A1.2 can be established with PILESIM.

Temperature levels, the heat pump performance coefficient and cooling machine efficiency, etc. are also calculated. The influence of long terms effects on the results can be assessed for up to 25 years. The temporal evolution of some energy rates and temperatures are printed in a file for the last simulated year. They can be then plotted thanks to a functionality of TRNSED.

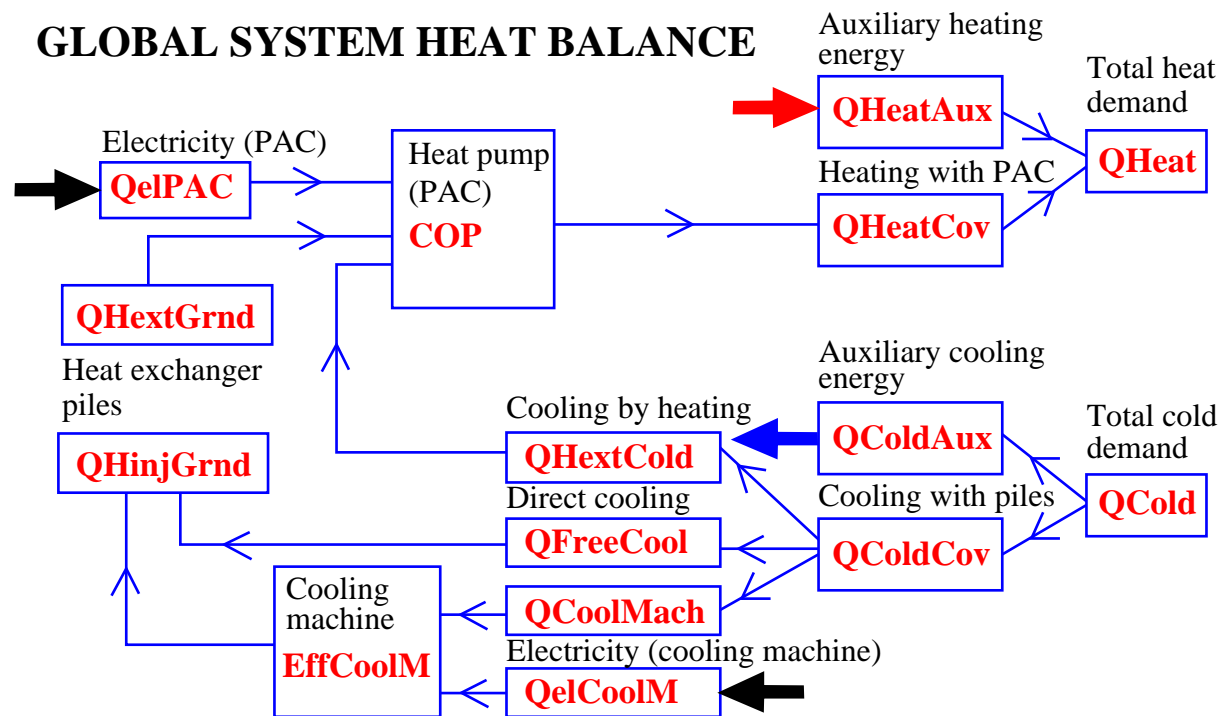
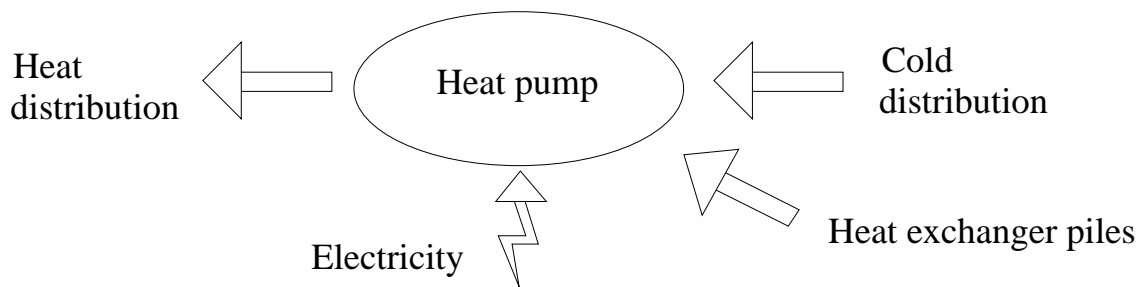

Figure A1.2 Sankey diagram which can be established with the quantities calculated with PILESIM

*A1.2.4 How does PILESIM calculate?*

Once the loading conditions are chosen and all the system parameters fixed, a simulation can be started. The undisturbed ground temperature is chosen for the initial conditions of the ground. The thermal simulation is performed with a time-step set to one hour. At each time-step, the operational mode of the system is determined, depending on the system type chosen, the current loading conditions and the system component's thermal performances (heat pump, cooling machine, heat exchanger piles, etc.). Three basic operational modes are possible (cf. Fig. A1.3).

**Operational mode: HEATING**



**Operational mode: DIRECT COOLING**

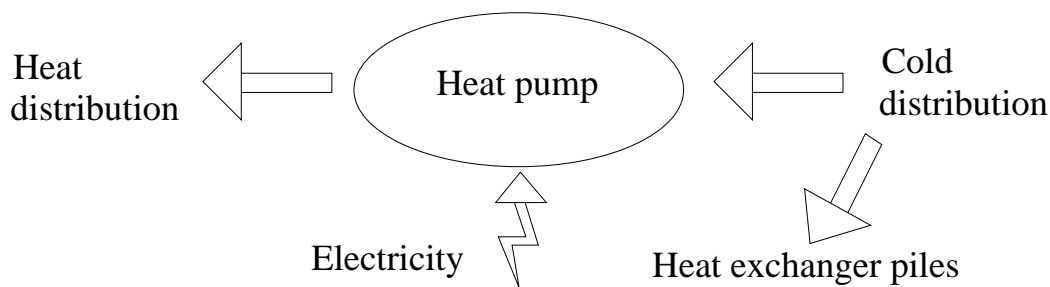

**Operational mode: COOLING**

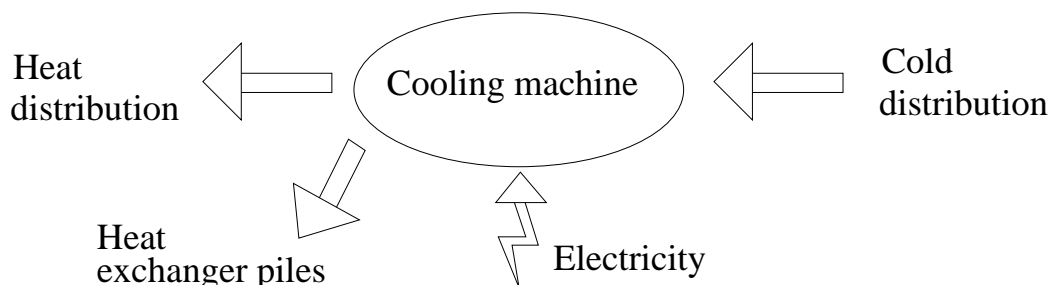

Figure A1.3 The three drawings illustrate the three basic operational modes of the heat exchanger pile system. The arrows indicate the direction of the (positive) energy fluxes

Heating and cooling can be simultaneously satisfied with each of these three operational modes. The mode that satisfies the greatest part of the heating and cooling demands is chosen.

If there is no cooling requirement when heating is needed or vice versa, the three basic operational modes are reduced to three simple situations:

- heating with the heat pump connected to the piles;
- direct cooling with the piles connected to the cold distribution;
- cooling with the cooling machine connected to the piles.

The heat pump performance coefficient and the cooling machine efficiency may depend on the temperature levels of the heat carrier fluid in the condenser and evaporator. The performance coefficient determines the heating power, with the help of the design electric power of the heat pump, set to a constant value. If the heating requirement is smaller, the heating power is decreased to match the heating requirement. As a result, the electric power consumed by the heat pump and the heat rate extracted at the evaporator are recalculated with the help of the performance coefficient. The heating power of the heat pump may also be reduced by the temperature constraint associated with the heat carrier fluid which circulates in the piles. This constraint requires that the fluid temperature in the piles never drops below a user given value, normally fixed at 0 °C. If this is not the case, the heat rate extracted by the heat pump is decreased until the fluid temperature satisfies the criterion. As a result, the heating power delivered by the heat pump is reduced. In consequence, an oversized heat pump will not yield much more heating energy per year than a correctly sized one. A temperature constraint is also given for the highest allowed fluid temperature in the pile flow circuit. The same kind of considerations apply for the cooling machine.

PILESIM assumes an optimal system control: the best operational mode is selected; the heating and cooling powers are adjusted to the heating and cooling demands if necessary, while the temperature constraints on the heat carrier fluid in the piles are satisfied. The influence of frequent starts and stops of the heat pump and cooling machine is not taken into account, although a penalty value can be specified on the performance coefficient and efficiency.

#### *A1.2.5 Main assumptions of the PILESIM simulation tool*

As previously mentioned, the system control in PILESIM is optimal. Other assumptions are related to the specificity of the simulation model used. The heat pump model is based on the model used in the MINSUN programme (MINSUN 1985). The heat exchanger piles are simulated with TRNVDSTP (PAHUD et al. 1996a). This model assumes a uniform arrangement of the heat exchanger piles in a ground volume, called store volume, which has the shape of a vertical cylinder. The thermal process in the ground is treated as a superposition of a global and a local problem. The global problem handles the large-scale heat flows in the store volume and the surrounding ground, whereas the local problem takes into account the heat transfer between the heat carrier fluid and the store. The global and local problems are solved for pure heat conduction with the use of the explicit finite difference method (FDM). The model, not suited for the computation of a ground water flow, uses approximations instead. They are based on the heat transfer induced by forced convection on a cylinder imbedded in a porous media (NIELD & BEJAN 1992). The main assumptions of PILESIM are:

- the number of heat exchanger piles is relatively large;
- the spatial arrangement of the heat exchanger piles is more or less regular;



- the ground area occupied by the heat exchanger piles has a shape which is more or less the shape of a circle or a square;
- the heat exchanger piles have about the same active length. (The active length of a heat exchanger pile is the length along which a radial heat transfer takes place.)

These assumptions imply that most of the heat exchanger piles are surrounded by other heat exchanger piles. In other terms, PILESIM is not suited to the simulation of a single heat exchanger pile or several heat exchanger piles arranged in a line. When the shape of the ground area occupied by the heat exchanger piles is far from being a circle or a square, or the pile arrangement is highly irregular, the average pile spacing; which is an input parameter to PILESIM, can be calibrated with another programme. (For example with TRNSBM (ESKILSON 1986; PAHUD et al. 1996b).)

### **A1.3 Conclusion**

PILESIM is a new simulation tool for heat exchanger pile systems developed with TRNSYS. People involved in the planning of a heat exchanger pile system should be able to use PILESIM, although they are not necessarily accustomed to TRNSYS. System thermal performances, utilisation potential of heat exchanger piles and a large variety of system designs can be assessed with PILESIM.

### **References**

- ESKILSON P. 1986. Superposition Borehole Model. Manual for Computer Code. Department of Mathematical Physics, Lund Institute of Technology, Lund, Sweden.
- FROMENTIN A., PAHUD D., JAQUIER C. & MORATH M. 1997. Recommandations pour la réalisation d'installations avec pieux échangeurs. Empfehlungen für Energiepfahlsysteme, Rapport final, Office fédéral de l'énergie, Bern, Switzerland.
- KLEIN S. A. et al. 1998. TRNSYS. A Transient System Simulation Program. Version 14.2. Solar Energy Laboratory, University of Wisconsin, Madison, USA.
- MINSUN 1985. Central Solar Heating Plants with Seasonal Storage. The MINSUN Simulation and Optimization Program. Application and User's Guide. International Energy Agency, Solar Heating and Cooling Programme, Task VII.
- NIELD D. A. & BEJAN A. 1992. Convection in Porous Media, Springer-Verlag, New-York.
- PAHUD D., FROMENTIN A. & HADORN J.-C. 1996a. The Duct Ground Heat Storage Model (DST) for TRNSYS Used for the Simulation of Heat Exchanger Piles. User Manual, December 1996 Version. Internal Report. LASEN - DGC- EPFL, Switzerland.
- PAHUD D., FROMENTIN A. & HADORN J.-C. 1996b. The Superposition Borehole Model for TRNSYS (TRNSBM). User Manual for the November 1996 Version. Internal Report. LASEN - DGC- EPFL, Switzerland.
- PAHUD D. 1999. PILESIM- LASEN: Simulation Tool for Heating / Cooling Systems with Heat Exchanger Piles or Borehole Heat Exchangers. User Manual. Laboratory of Energy Systems, Swiss Federal Institute of Technology in Lausanne, Switzerland.